

ew

DSI



DYNA-TRAIL

INSTALLATION, OPERATING, AND SERVICE INSTRUCTIONS SUBURBAN DYNA-TRAIL FURNACES

For Model Numbers
NT-30M—NT-30MD
NT-24M—NT-24MD

- This book contains complete instructions for installation and operation of your furnace. Keep with unit at all times.
- Should you require further information, contact your dealer or nearest Dyna-Trail Service Center

SUBURBAN MANUFACTURING COMPANY

Post Office Box 399
DAYTON, TENNESSEE 37321

Read This Entire Book

Each item included in your Dyna-Trail furnace unit is of high quality. Properly installed, your furnace will give years of satisfactory, dependable service and economical operation. To simplify any problems of installation, we urge that you read carefully these step-by-step instructions.

Foreword

The design of this unit has been certified by The American Gas Association and The Canadian Gas Association. In order for this furnace to operate according to your expectation and in conformity with generally accepted safety regulations, installation and service instructions outlined in this book **MUST BE FOLLOWED**. Failure to comply with installation and operation instructions will void the responsibility of the manufacturer.

KEEP THIS BOOK in a safe place, because it is an important collection of facts and figures compiled to assure you a satisfactory heating installation that will add to your living pleasure. This book is intended to be a permanent part of your furnace installation and should be preserved in a convenient location for ready reference.



DAYTON, TENNESSEE



IMPORTANT

Read the following before installing furnace.

1. Do not install furnace unless the tube on the vent cap overlaps the exhaust tube on furnace at least ½".
2. Do not install vent cap upside down. The words SUBURBAN and DAYTON, TENN. must be installed right side up. (See fig. 2.)
3. Do not omit or substitute the special 3" screw on exterior vent cap. This anchors the furnace to the vent cap and outer skin of the coach. (See fig. 2)
4. Do not install the manual shutoff valve with flare at top position.
5. Do not use any compound on threaded joints that is not resistant to liquid Petroleum Gas.
6. Do not make any pipe connection without afterwards checking for leakage. (Use soap and water solution.)
7. Do not use open flame to check for leaks.
8. Do not attempt to alter the furnace for a positive ground system.
9. Do not install the furnace with floor coverings under the cabinet.
10. Do not connect the furnace direct to 110 volts A.C.
11. Do not use unauthorized gauge wire. 14 gauge wire is required.
12. Do not replace any wiring on the furnace with anything less than type 105 C wire or its equivalent.
13. Do not install furnace without adequate return air. (55 sq. inches, minimum)
14. Installation of furnace must be in accordance with local codes. (See par. I under General Notes.)
15. Do not install unless clearances from combustible materials are adhered to. (See par. M under General Notes)
16. Do not attempt to ignite a direct ignition furnace with a match, Butane torch, or flint type ignitors. (Follow Lighting Instructions on page 11)
17. Do not operate the furnace with electrode wire or the electrode assembly disconnected.
18. Do not operate the furnace through a battery charger.
19. Do not use a screwdriver or metal object on any portion of the electrode assembly while furnace is in operation.
20. Do not operate the furnace if the spark from the electrode is jumping to the flame sensor portion of the electrode assembly. (See fig. 8, page 18 for proper gapping of the electrode assembly)
21. Do not remove module board without first discharging board. (See Service Hints, page 13)
22. Do not attempt field repairs to the module board.
23. Do not make design changes or modify the operation of the furnace in ANY way.
24. Do not convert furnace to natural gas.
25. Preventive maintenance to the furnace is recommended at least once a year. (See Maintenance and Cleaning, page 12)
26. Do not install furnace where it cannot be easily removed for service.

Thank you for reading this far—Please read entire manual before installing furnace.

INSTALLATION, OPERATING, AND SERVICE INSTRUCTIONS

INTRODUCTION

The furnace in your recreational vehicle is a direct vent system furnace design certified by the American Gas Association and the Canadian Gas Association for safety and performance. Your furnace is one of the following models:

NT-30M-12 Volts DC, 30,000 BTU/hr. Input
NT-30MD (Dual) 12 Volts DC or 115 Volts AC

NT-24M-12 Volts DC, 24,000 BTU/hr. Input
NT-24MD (Dual) 12 Volts DC or 115 Volts AC

These models are the same as far as physical size, function, installation, operation and general maintenance. The most significant difference in either of the models is the electrical system. 12 Volt DC models versus dual 12 Volt/115 Volt models.

NOTE: These furnaces are design certified for L.P. Gases only.

INSTALLATION ALL MODELS

In the installation of these units, serviceability after the installation must be kept in mind.

INSTALLATION – Directly Against Outer Skin Of Vehicle:

- A. Locate the furnace near lengthwise center of the coach.
- B. Cut opening through inner wall 13"x14". This will allow the rear of the furnace to be installed against the outer skin of the coach. (See fig. 1)
- C. Cut two 2¼" dia. holes through outer skin of coach as shown in Fig. 1. For installation using vent extension tubes, see Fig. 3.
- D. Put furnace in place, making sure that rear of furnace cabinet is firmly against outer skin of coach.
- E. Fasten furnace to floor of coach using two holes provided in front plenum area of furnace cabinet (Fig. 1)

INSTALLING THE VENT CAP

- A. Caulk around vent cap assembly as shown in figure 2.
- B. Insert vent cap assembly over exhaust and intake tube. **Minimum overlap of ½" is a must.** (See fig. 2)
- C. Attach vent cap to outer skin of coach with 4 screws provided. (See fig. 2)
NOTE: Do not install vent cap upside down. The words Suburban and Dayton, Tenn. must be installed right side up. (See fig. 2)
- D. Attach vent cap assembly to furnace with special 3" screw provided. Insert screw through hole provided in exhaust opening of vent cap and secure to bracket in exhaust tube of furnace. This anchors the furnace to the vent cap and the outer skin of the coach. (Fig. 2)

NOTE: Under no condition should combustion air be taken from the living area of the coach.

INSTALLATION USING VENT EXTENSION TUBES

When it is not possible to install the furnace against the outer skin of the coach, extension tubes must be used to connect the exhaust tube and the combustion air tube to the vent terminal on the outside of the coach.

- A. Attach vent extension tubes to furnace as shown in Fig. 3. Secure each extension tube to tubes on furnace as shown.
- B. Cut two 2½" dia. holes through outer and inner wall of coach. (Fig. 3)
- C. Put furnace in place, making sure that extension tubes terminate flush with outer skin of coach.
- D. Fasten furnace to floor of coach using the two holes provided in the plenum area of the furnace cabinet (Fig. 1)
- E. Install the vent cap as described in vent installation (Fig. 2)

GENERAL NOTES

After the furnace has been secured in place and the outside vent installed (Fig. 2), the installation may now be completed by the following program:

A. Connect the gas supply to the furnace at the manifold. Be sure that the manual shutoff valve is outside of the furnace jacket and easily accessible.

NOTE: Compound used on threaded joints must be resistant to liquid petroleum gas.

B. Connect the 12 Volt DC power supply to the quick connect pigtail provided. The wires are color coded, red for positive (+) and yellow for negative (-). This polarity must be observed so the furnace motor will run with the proper direction of rotation to insure correct air delivery (see wiring diagram, page 16).

NOTE: This unit is designed for negative ground 12 Volt DC system only. Do not attempt to alter the unit for a positive ground system

C. This furnace is not furnished with a built-in 115 Volt AC power supply. If Suburban power supply is used, it must be secured to furnace cabinet as shown in Fig. 4.

D. Connect the black and white wires of the power supply to the 115 Volt AC power supply. **NOTE: Wires are color-coded for polarity; see wiring diagram, page 17.** This unit is equipped with an internal relay which automatically switches the furnace's power supply source from DC to AC when the AC power is connected to the coach. The relay automatically switches back to DC when the AC power supply is disconnected.

E. Locate the room thermostat approximately 4½ ft. above the floor on an inside bulkhead where it is not affected by heat from any source except room air. Connect thermostat wires as shown in wiring diagram.

F. Be sure all wiring to the furnace is of heavy enough gauge to keep voltage drop through it to a minimum. No. 14 gauge wire is recommended.

NOTE: Unit must be grounded in accordance with NEC when AC is used.

G. For side ducts, it is required that a minimum of 36 square inches of duct area be provided, (minimum 3 ducts x 4" diameter) and for the under floor ducting, a minimum of 48 square inches. The purpose of the duct area is to keep the furnace from cycling on limit. Caution must be used in this area where extra long duct work or irregular shaped duct work is used to prevent such a condition.

NOTE: For air temperature rise, see information sticker on top of furnace cabinet.

H. A drip leg should be installed upstream of the manual shutoff valve exterior to the unit casing. After the furnace has been connected to the gas supply, all joints must be checked for leaks. **CAUTION: Never check for leaks with open flame.** Turn on the gas and apply soapy water to all joints and watch to see if bubbles are formed.

I. All installations of the furnace shall be in accordance with local codes and regulations. In absence of local code, the following American National Standard applies: Recreational Vehicles A119.2-1975. Also, the unit must be electrically grounded in accordance with the National Electrical Code ANSI C1-1975.

In Canada, the appliance must be installed in accordance with:

- (1) Standard CGA10.1/Z240.4 - Gas equipped recreational vehicles and mobile housing.
- (2) CSA Standard Z240.6.2-Electrical requirements for recreational vehicles.
- (3) Any applicable local codes and regulations.

J. To put the furnace in operation, follow the lighting instructions on it.

K. The cold air return for this furnace must be approximately 55 square inches free area.

L. Usually the furnace will be installed under a counter. For easy access to it, the furnace enclosure should consist of a door through which the furnace can be serviced.

M. Clearances from combustible material adjacent to the unit must not be less than the following:

NOTE: Floor coverings should be removed from under furnace cabinet.

Model NT-30M-12 Volt DC
 Sides Top Front Bottom Back
 1'' 0'' 0'' 0'' 0''

Model NT-24M-12 Volt DC
 Sides Top Front Bottom Back
 1'' 0'' 0'' 0'' 0''

Model NT-30MD-115 Volt AC
 Lt. Side Top Front Bottom Back Rt. Side
 1'' 0'' 0'' 0'' 0'' 6''

Model NT-24MD-115 Volt AC
 Lt. Side Top Front Bottom Back Rt. Side
 1'' 0'' 0'' 0'' 0'' 6''

NOTE: 6'' clearance is to accomodate Power Pak convertor.

NOTE: If any of the original wire that is supplied with the appliance must be replaced, it must be replaced with type 105 C wire or its equivalent.

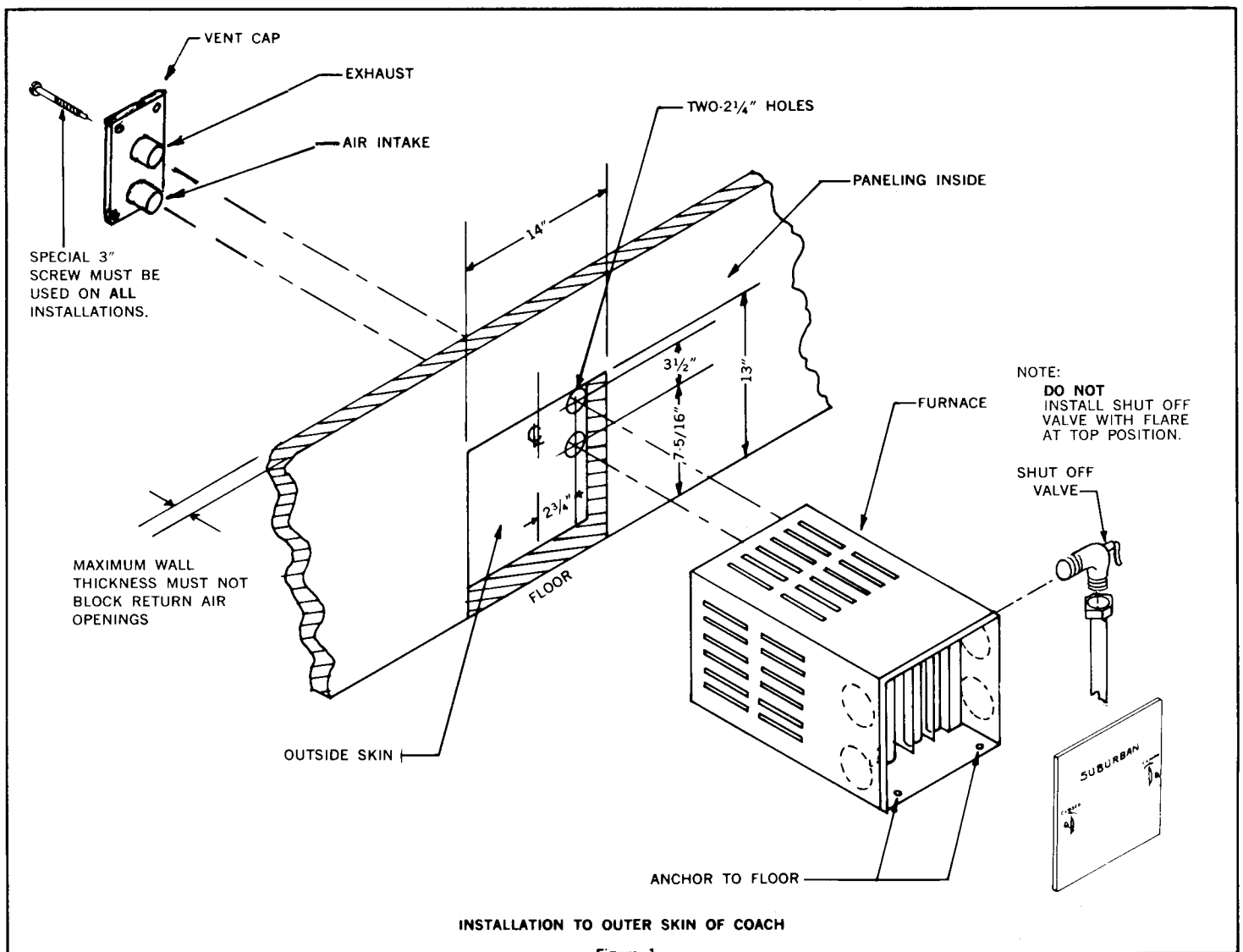

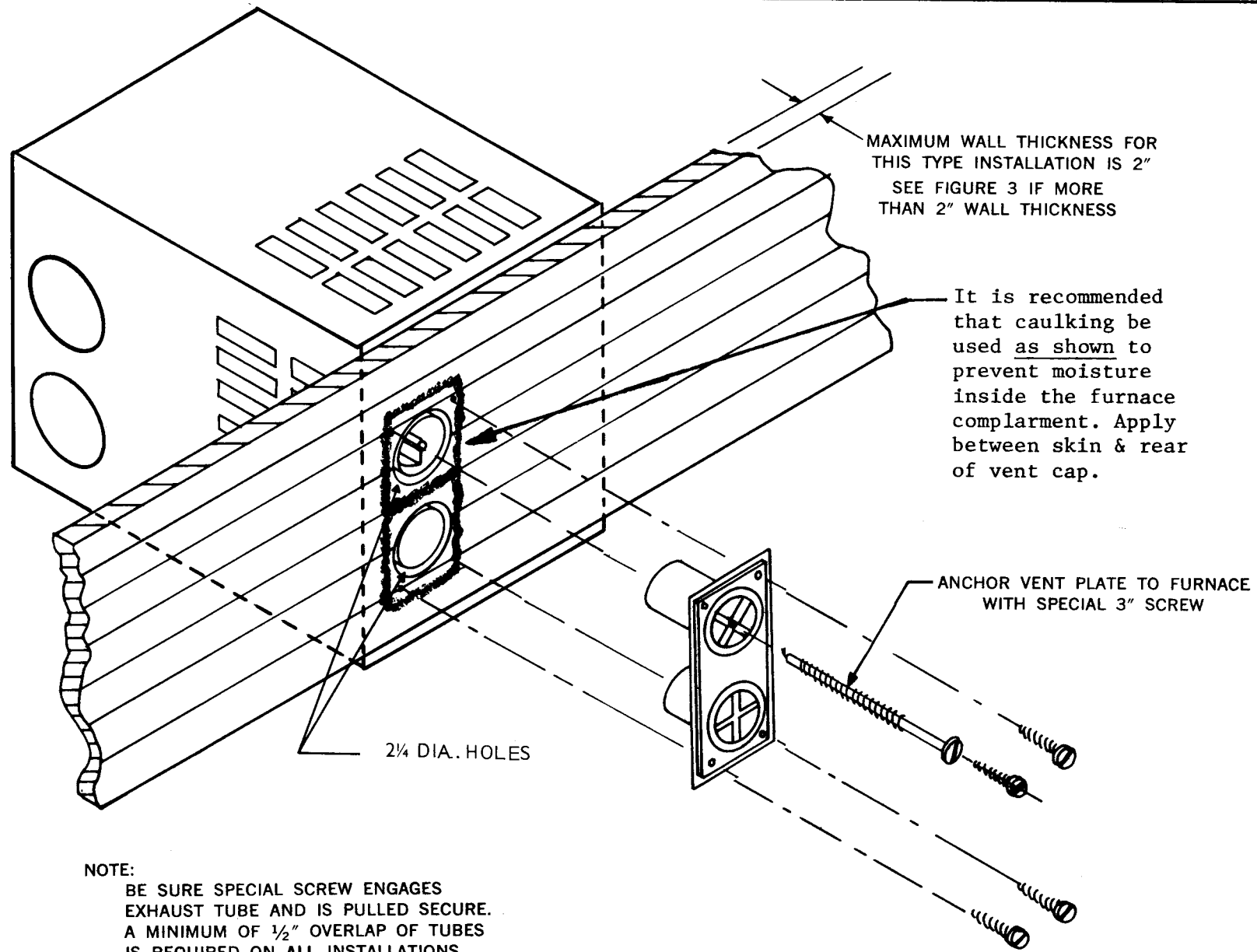

VENT CAP INSTALLATION

Figure 2

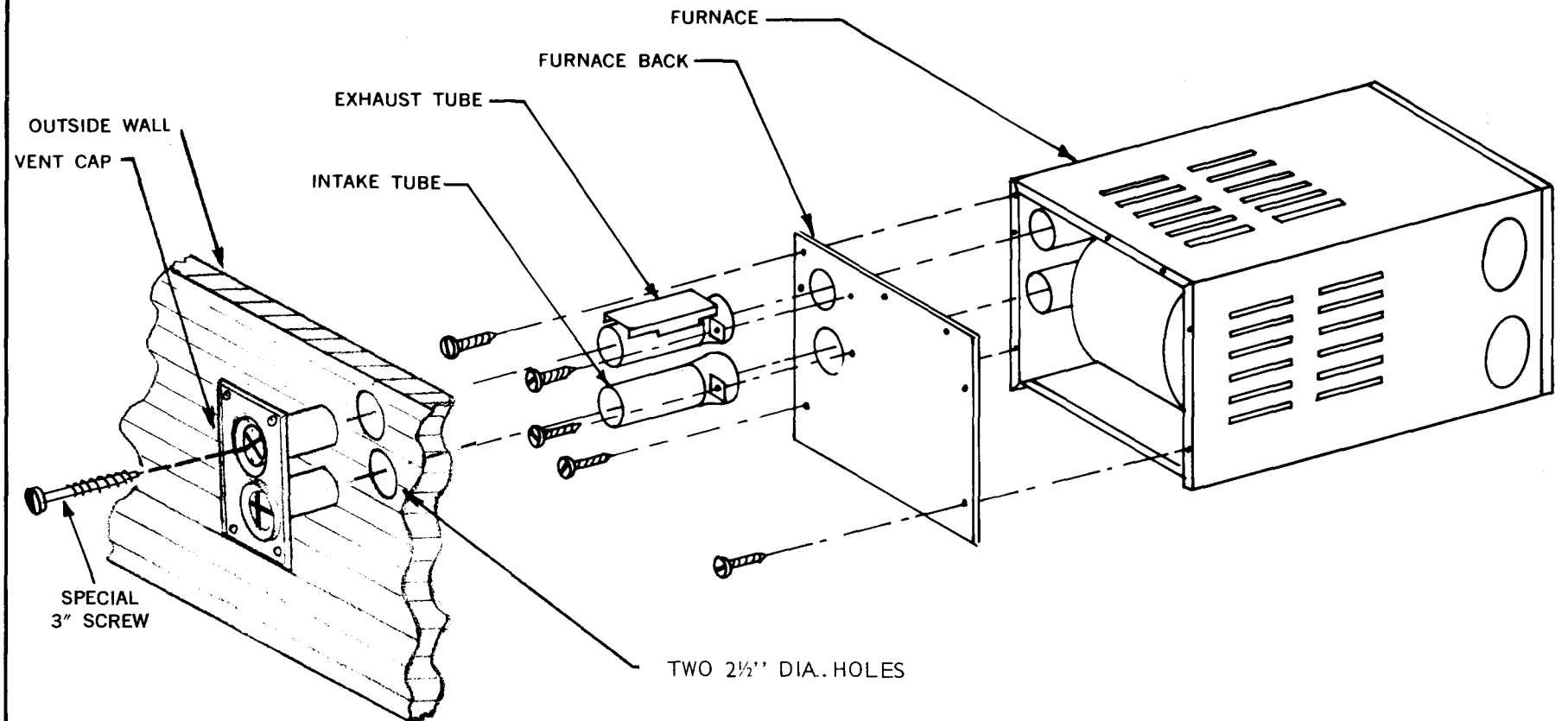

- A. Remove furnace from carton and install furnace back with screws provided.
- B. Insert exhaust tube and intake tube through furnace back and engage exhaust and intake tube on furnace.
- C. Secure tubes to furnace back through lug on side of tubes.
- D. Put furnace in place, making sure that tubes terminate with outside surface of wall.
- E. Fasten furnace to floor of coach using two holes provided in front plenum area of furnace cabinet (See Fig. 1).
- F. Install vent cap as shown in (Fig. 2).
- G. Maintain 3/8" clearance around exhaust tube and air intake tube to any combustible material.
- H. Maximum extension tube length—9".

EXTENSION TUBE INSTALLATION

Figure 3

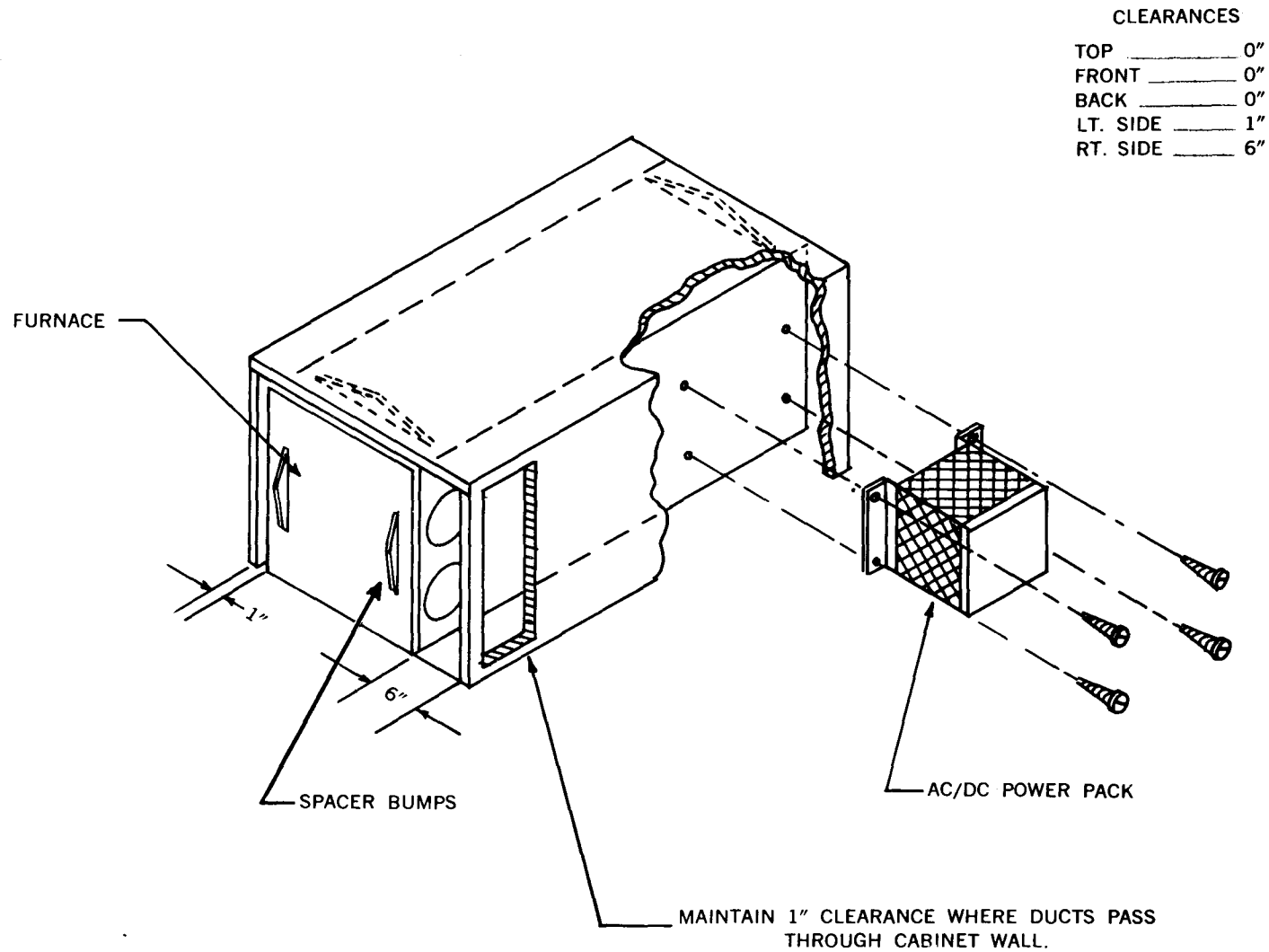

INSTALLATION—AC/DC POWER PACK

Figure 4

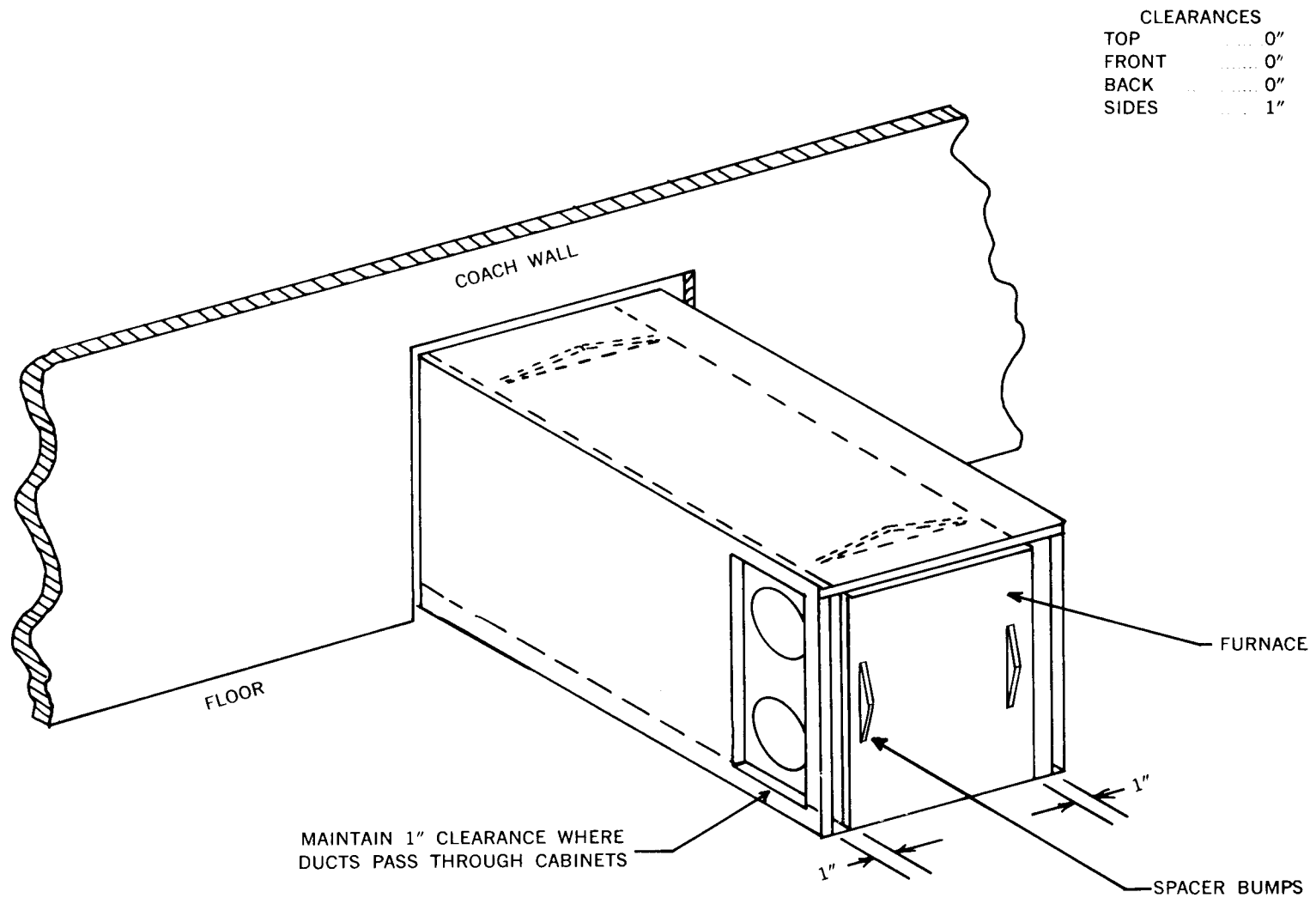

STANDARD INSTALLATION—12V—DC

Figure 5

OPERATING INSTRUCTIONS

LIGHTING INSTRUCTIONS

- (1) To light the furnace, turn the manual valve to the OFF position and wait 5 minutes with blower running. (Set thermostat above actual temperature to operate blower.)
- (2) After 5 minutes, set the thermostat to the OFF position.
- (3) Open manual valve. (Correct operating characteristics depend on this valve being positioned fully open. Never attempt to operate with valve partially closed.)
- (4) Set thermostat on desired temperature.
- (5) Allow 15 seconds for main burner to light.
- (6) If burner does not light, set thermostat on OFF and repeat steps 1 through 5.
- (7) After 3 attempts with no ignition, go to shutdown and determine cause. **NOTE: Do not continue to cycle furnace through thermostat in an attempt to get ignition.**

TO SHUT DOWN

- (1) Turn Manual valve to the OFF position.
- (2) Set thermostat on OFF.

BURNER ADJUSTMENT

To adjust primary air to the main burner, the small sheet metal cover found just below and to the right of the lighter opening must be removed. Behind the cover is a slotted screwhead. With a screwdriver, turn screwhead counterclockwise for less primary air and clockwise for more primary air. A symptom of too much primary air will be a howling or screeching noise when the burner is on (reduce air to correct). A symptom of too little primary air will be sooting on the exterior vent and a distinct yellow and floating flame (increase air to correct). A hard blue flame is the sign of correct adjustment. **NOTE: If a sooting condition cannot be corrected by the air adjustment on the burner, discontinue use of furnace until problem can be corrected by a service agency.**

SEQUENCE OF NORMAL OPERATION

- (1) When the thermostat calls for heat, the blower motor is energized immediately.
- (2) As the blower motor reaches approximately 75 percent of the normal r.p.m. (within 3 to 5 seconds) the microswitch, in response to the air flow, will engage allowing current flow to the solenoid valve and the spark ignition system.
- (3) The current to the valve opens it and allows gas to the main burner. The spark then ignites the main burner.
- (4) After main burner ignition, the flame detector will sense the presence of flame (usually within 7 seconds) and deenergize the lockout feature. If the main burner does not ignite or the flame detector does not deenergize the lockout feature within 7 seconds, the unit will go into lockout. At this time, it will be necessary to set the thermostat on OFF and repeat steps 1 through 6 of the lighting instructions.
- (5) After 3 attempts with no ignition or main burner continues to go off within 7 seconds, go to shutdown and determine cause. (See service hints)
- (6) If within a period of approximately 2 minutes after the main burner is lit, the thermostat is turned back, both the blower motor and solenoid valve are deenergized. However, if the furnace continues to run longer than 2 minutes, which it normally should, a slight snap can be heard from within the casing. The snap is caused by the fan switch as it changes its position. After this occurs, if the thermostat is satisfied or turned back, the solenoid valve will close, the flame on the main burner will go out, but the blower will continue to run for a short period of time and will then shut off. The purpose of this is to remove most of the remaining gases from the heat exchanger. Be assured that this period of blower override is a part of the unit's normal operation.

FAN SWITCH

The purpose of the fan switch is to control the sequence of the blower operation. The fan switch is a two pole switch. When the bimetal

disc of the fan switch is heated to the operating temperature, the switch closes. This completes a circuit through the motor from a direct source. The blower will continue to run as long as the chamber is hot even though the thermostat is satisfied and the main burner is off. When the chamber cools, the fan switch changes back to its original position and shuts the blower off. If blower and burner shut off simultaneously after thermostat is satisfied, then the fan switch failed to change over. This is a symptom of a faulty switch—replace it.

LIMIT SWITCH

The purpose of the limit control is to turn off the gas to the main burner if for any reason the furnace becomes hotter than that which is safe. Improper operation of the furnace due to the limit control does not always indicate a defective control. If the circulating air is blocked or only partially so, the limit control will function and cause the main burner to cycle. Cycling on the limit is not always undesirable—if it happens only occasionally. This is a good indication of safe operation and will most likely happen on a warm day. If cycling happens too often or for an extended period, the circulating air system should be thoroughly cleaned.

If for any reason the limit control is found to be defective, there is no recommended method of repairing it. Because of its importance for safety reasons, it should be replaced with a new one. CAUTION: NEVER SHUNT THE LIMIT CONTROL EVEN FOR ONLY TEMPORARY OPERATION.

MICROSWITCH

The microswitch has two purposes:

MAINTENANCE AND CLEANING

We recommend that the furnace be inspected and thoroughly cleaned by a qualified service agency before each heating season. This would include the combustion chamber, the main burner, the blower assembly, and all control parts. A careful inspection of all gaskets should be made and if any gaskets show signs of leakage or deterioration, they should be replaced.

Cleaning of the chamber and main burner will be required if the unit has been allowed to operate with a high yellow flame. The yellow flame is due to incomplete combustion (lack of air) and

(1) It is an AIR PROVER. It operates in response to the flow of air generated by the blower. Hence, if for any reason the air from the blower is not sufficient, the switch will not operate. This may be caused by a slow motor due to low voltage, restricted return air, inadequate duct discharge area, or lint accumulation on the blower wheel. (2) The switch allows time for the blower to pull in a sufficient amount of air to support combustion before it engages. Once it engages, the solenoid valve opens, gas flows to burner, and ignition occurs.

BLOWER ASSEMBLY

Although one motor drives all wheels, the blowers are separate. The combustion-air blower is sealed so as to allow no passage of air between it and the circulating room-air blower. The combustion-air blower draws air from the outside atmosphere, discharges it into the combustion chamber, and forces the combustion products out the exhaust tube. The circulating room-air blower pulls return air in and forces it across the heat chamber, discharging into the area to be heated.

AUTOMATIC SOLID STATE RECTIFIER SYSTEM ON DUAL VOLTAGE MODELS

Two diodes are mounted on a larger heat sink and combine with the transformer to create a full-wave rectifier which converts 115-volt AC to 12-volt DC.

A single-pole, double-throw relay switches the unit from AC to DC/DC to AC automatically. (See wiring diagram, page 17, figure 7)

will deposit a soot formation inside the chamber and on the main burner.

To clean the chamber, main burner, blower assembly and controls, the chamber assembly must be pulled from the furnace. (See instructions for removing chamber.)

The furnace is equipped with an oiled, sealed motor and requires no oiling.

COMBUSTION CHAMBER REMOVAL

The combustion chamber must be removed from the front.

- (1) Shut off gas at gas bottle.
- (2) Disconnect power supply (quick disconnect plug, right side of cabinet.)
- (3) Disconnect gas line from manual shutoff valve.
- (4) Remove shutoff valve from side of furnace.
- (5) Remove cabinet front.
- (6) Remove shipping screw securing chamber

shield to cabinet (lower right corner).

(7) Remove the vent cap screws (outside) to free exhaust tube.

(8) Pull chamber forward and out of cabinet.

NOTE: Combustion chamber removal for NT-24MD and NT-30MD same as NT-24M/NT-30M.

SERVICE HINTS, DIAGNOSIS AND CORRECTIVE MEASURES

NOTE: To service, furnace must be removed from cabinet.

A. COMPLAINT—NO HEAT

(1) Thermostat off—Check to be sure thermostat is calling for heat. Wire to thermostat could be off terminal.

(2) Gas supply—Be sure manual gas valve is in the open position (level parallel to gas line).

(3) Electrical connections and power—Battery must be charged. If battery is low, there will be sufficient power to run the blower, but not enough to run the blower at full speed. If blower doesn't run at its prescribed speed, the microswitch cannot be engaged and gas will not flow to the main burner nor will the spark begin. Be sure the connection of the voltage lines in the terminals are tight.

(4) Malfunctioning microswitch—Be sure the microswitch is sailing in far enough to open the solenoid valve and to energize the spark module board. If the switch is not sailing in, clean any dust or dirt from the actuator pin. Other reasons for switch not sailing in are:

a. Insufficient blower speed (slow motor due to low charged battery, faulty motor, lint and dust accumulation on the blower wheels, or restriction of return air to furnace). Check wiring in accordance with unit's wiring diagram to assure the proper polarity of the 12 Volt DC power supply is observed. This polarity must be observed so the motor will run the proper direction of rotation to insure correct air delivery.

b. Faulty microswitch—Replace switch if valve doesn't open when switch is manually engaged. Switch should also be replaced if battery is fully charged and blower motor running at top speed fails to engage switch within 6 to 7 seconds.

c. Inadequate duct discharge area. (See duct requirements on page 5, paragraph G under general notes.)

NOTE: To service switch, combustion chamber must be pulled out.

(5) Gas valve—With test light, check gas valve terminals. If current is present but valve is not opening (when microswitch engages), replace gas valve. The chamber must also be removed to check the above. To replace the gas valve, it will be necessary to remove the chamber assembly from the furnace metal cabinet.

(6) Blower not operating—Check for burned-out motor. On dual voltage model furnaces, the AC/DC switching relay could be faulty—check by shorting across terminals 2 and 4. If relay clicks but motor fails to start, replace motor. If no click is evident, replace relay.

(7) Short cycling (fan switch)—If burner and fan shut off simultaneously when the thermostat is satisfied, it indicates a defective fan switch. Replace switch (chamber must be removed).

(8) Defective relay—Relay may be faulty if motor fails to start when thermostat calls for heat. This will be evidenced by a click when the thermostat is raised and motor fails to operate.

(9) Ignition failures—**Cautions:**

1. Never operate the furnace with the electrode wire disconnected nor with the electrode assembly removed from the furnace.

2. Never use a battery charger to check out an electronic ignition furnace.

3. Never use a screwdriver on any part of the electrode assembly while furnace is in operation.

4. Be certain that the spark from the electrode never reaches the flame sensor portion of the electrode assembly.

5. Be sure the electrode assembly screws are snug at all times, especially after the electrode has been removed and reinstalled.

6. **Discharge Module Board Before Removing From Furnace.** This is accomplished by placing a screwdriver on the terminal coming out of the coil (where electrode wire connects) and grounding it to some portion of the furnace.

7. If the module board is found to be defective, it must be replaced—it is not field repairable. Any attempts to repair the board may alter the board and cause it to operate in an unsatisfactory manner.

8. Insure that the gap between electrode and ground is always 1/8". The gap between the ground and the flame sensor should be approximately twice the gap between electrode and ground to insure no sparking to sensor. Sparking to sensor will damage module board. (See fig. 8, page 18)

The electronic ignition system is made up of three main parts. The module board, the electrode assembly and the electrode wire. The module board is the brain of the electronic ignition system and it has three functions:

(1) When the blower reaches full RPM, a circuit is completed to the module board and the module board produces a spark as indicated by the small neon bulb on the board as it flashes.

(2) At the same instant, the board also allows a completed circuit to the gas valve.

(3) The module board also performs the lock-out function in cases where the spark fails to light the burner after five to seven seconds. When lockout occurs, the spark stops and the voltage from the module board to the gas valve is discontinued and the valve closes. The unit will remain in lockout and the blower will continue to run until the thermostat is turned off.

It is important to determine the type problem being experienced and then the proper check-out procedure can be made. The following is a list of problems, how to identify in which area the problem is located, and how to correct it:

(1) **Electrode not sparking**—with blower running and microswitch engaged, check the following:

a. Check for proper voltage at spark module board after the blower motor reaches full RPM. If no voltage, check back through circuit to determine cause.

b. Voltage is present but no spark at electrode. Check electrode wire connections.

c. Wire connections OK but electrode wire does not show continuity through it—replace electrode wire.

d. Electrode wire does show continuity through it—check electrode gap. (See fig 8, page 18)

e. Electrode gap OK—check electrode assembly for possible cracks or carbon on tip of electrode.

f. Electrode OK—Replace module board.

(2) **Electrode sparking but gas not coming through burner:**

a. Check to see if voltage is coming out of module board to gas valve. If no voltage and wire connections are OK, replace module board.

b. Voltage is coming out of module board to gas valve but gas valve does not open—replace gas valve.

(3) **Electrode sparking and gas valve opening but burner will not light:**

a. Check to see if gas is coming through burner. If no gas is coming through the burner, check for obstruction in gas line, in main burner orifice, or in main burner.

b. Gas is coming through burner but spark will still not ignite burner—check gas pressure to be certain that it is 11 inches water column at furnace.

c. Gas pressure OK—check for obstruction in main burner, check to be sure that air shutter is not completely closed and be sure electrode is positioned approximately 1/4 of an inch above and directly over one of the sawed slots on the main burner.

(4) **Burner ignites but goes off and into lock-out:**

a. Check to be certain that flame sensor is over one of the slots in the main burner and that the main burner flame is burning against the tip of the flame sensor—adjust by sliding burner in direction necessary.

b. Burner still goes off and into lockout, check wire connections at flame sensor and at module board.

c. Wire connections OK—check continuity through flame sensor wire.

d. Continuity of flame sensor wire OK—check with micro amp meter in series with flame sensor wire to be certain that the flame sensor is putting out at least seven micro amps within seven seconds after the burner is ignited. Replace electrode assembly if test is negative.

e. Flame sensor OK but burner still goes off and into lockout—replace module board.

(5) **Repeated module board failures:**

a. Check to be certain that the electrode spark

is not sparking against the flame sensor portion of the electrode assembly. (See figure 8 for correct gapping)

- b. Check to be sure module board is not shorted to the chamber wrapper.
- c. Be sure fish paper insulator covering the electrode wire connection on the coil of the module board is in place.
- d. High voltage—14.5 Volts DC, maximum.

(6) Customer complains of unit going into lock-out only once in a while.

a. We have found that lockout can occur if the gas pressure fluctuates at the time the thermostat calls for heat. Pressure fluctuations can be caused by a malfunctioning gas bottle regulator, an obstruction or a kink in the gas line and moisture in the gas bottle regulator or in the gas lines.

It is difficult to check for these fluctuations that will not noticeably affect any other appliance in the coach. However, isolating the furnace from the coach gas system will determine if the gas system is responsible. This isolation procedure can be done by connecting a separate upright bottle, regulator and gas line directly to the furnace, eliminating the coach gas system. If the occasional lockout still exists, then the furnace should be thoroughly tested to determine the cause; however, if the furnace works properly on this separate system, then the coach gas system should be checked.

When moisture in the gas system is suspected as being the problem, especially where the horizontal type gas bottle is being used, the following steps should be taken to prepare the gas system against further moisture problems.

Corrective Measures:

1. Disconnect gas bottle and drain it completely dry of all gas and moisture
2. Disconnect and blow out all gas lines completely dry.
3. Install a new pressure regulator on the gas bottle.
4. Add the drying agent. $\frac{1}{2}$ pint of methanol alcohol per 100 pound bottle capacity is recommended.

Precautions:

5. Never fill the gas bottle over 80%.
6. Do not use gas bottle completely dry to avoid using up the drying agent.

We have found the above procedures to be effective in over 95% of all occasional lockout problems that we have encountered, especially where the horizontal gas bottle is used. All of

these steps must be performed as described for the preparation of a contaminated gas system to be 100% effective.

B. COMPLAINT—EXCESSIVE NOISE

1. Blower out of balance—replace blower.
2. Motor hum—replace motor.
3. Air adjustment—a screeching or howling noise while burner is on is due to excessive primary air. To adjust for less air, see instructions on page 11.

C. COMPLAINT—ERRATIC BLOWER OPERATION

1. If blower is going off and on, check the following:

- a. Thermostat points—if points are opening and closing, see service hints, line 2 below.
- b. If thermostat points are remaining open or closed, the internal overload switch in the motor is defective—replace motor.

2. If thermostat points are observed opening and closing rapidly when furnace first starts, check the following:

- a. Quick disconnect plug on side of furnace. Plug must be wired as shown on electrical diagram.
- b. Miswiring at thermostat relay (See wiring diagram).
- c. Shorted gas valve—If furnace runs properly with wires at gas valve disconnected, replace gas valve.
- d. Short in wiring—check all connections including thermostat.

D. MAIN BURNER WILL NOT CYCLE OFF

1. Check thermostat points—points should break clearly.
2. Check solenoid valve—valve may be stuck open. If so, replace. Do not attempt to repair valve.

E. COMPLAINT—UNIT WILL NOT OPERATE

1. Check all wiring to assure proper connections or detect possible shorts.
2. On dual voltage furnaces, check the following:
 - a. Proper wiring connections to AC/DC convertor.
 - b. Transformer for burnout or shorts.
 - c. Diodes.
 - d. AC/DC switching relay.

NOTE: On dual voltage units, replace the entire convertor under the following conditions:

- a. Source of problem cannot be traced to any one convertor component.
- b. Excessive voltage or lighting has been placed on the input of the convertor

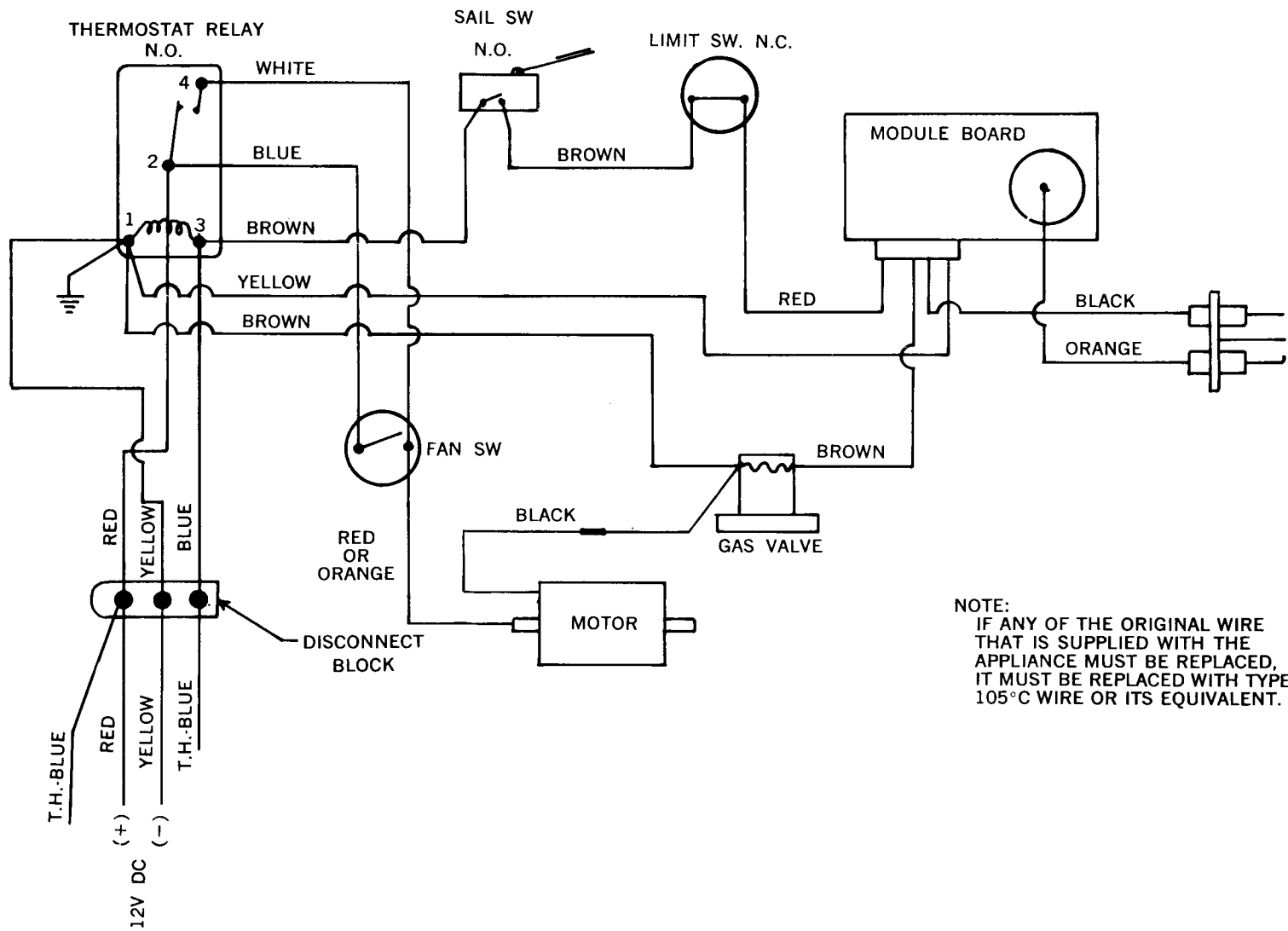

ELECTRICAL WIRING DIAGRAM
 12 VOLT UNITS—NT-30M, NT-24M

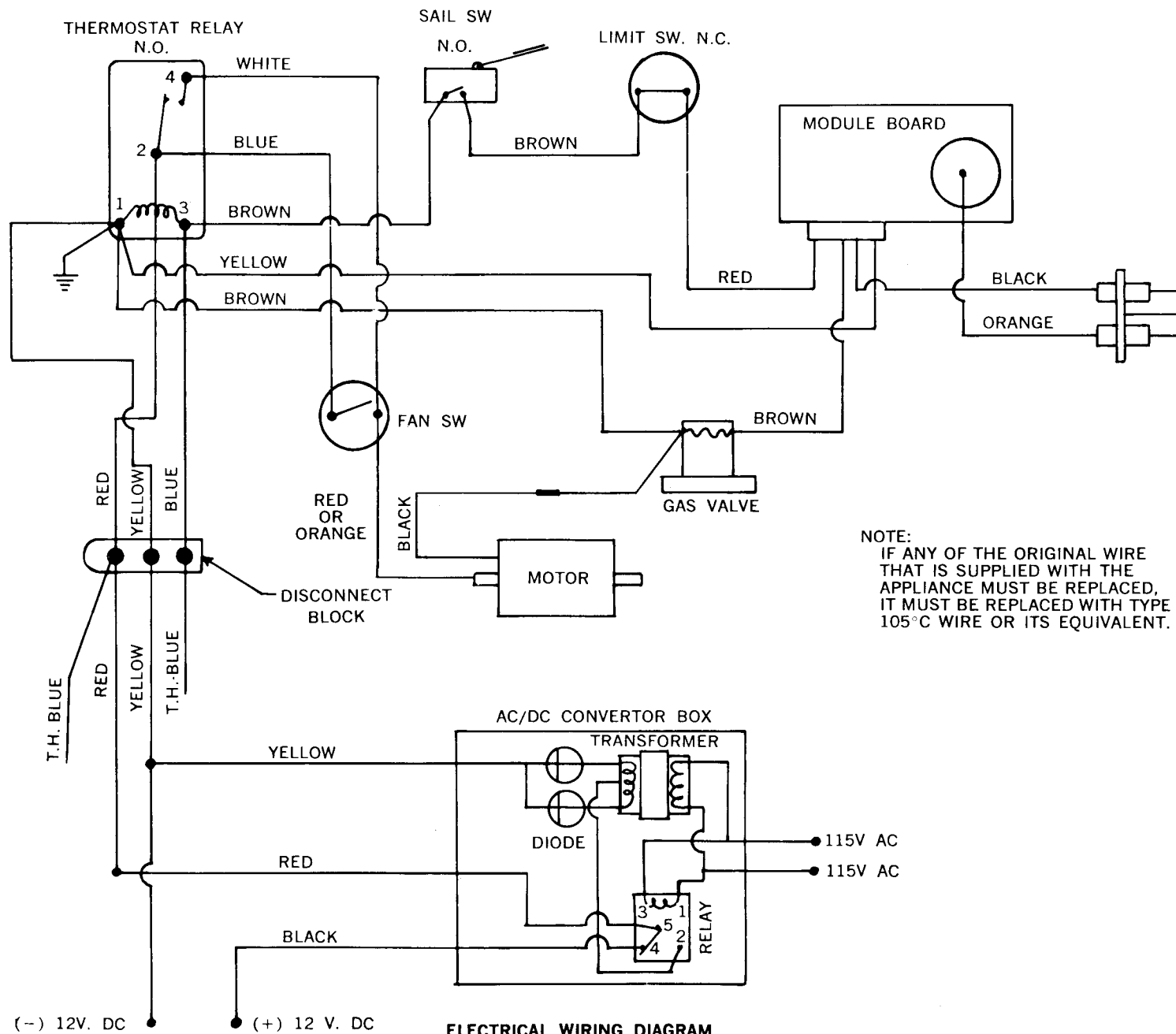

ELECTRICAL WIRING DIAGRAM
 DUAL VOLTAGE UNITS—NT-30MD, NT-24MD

Figure 7

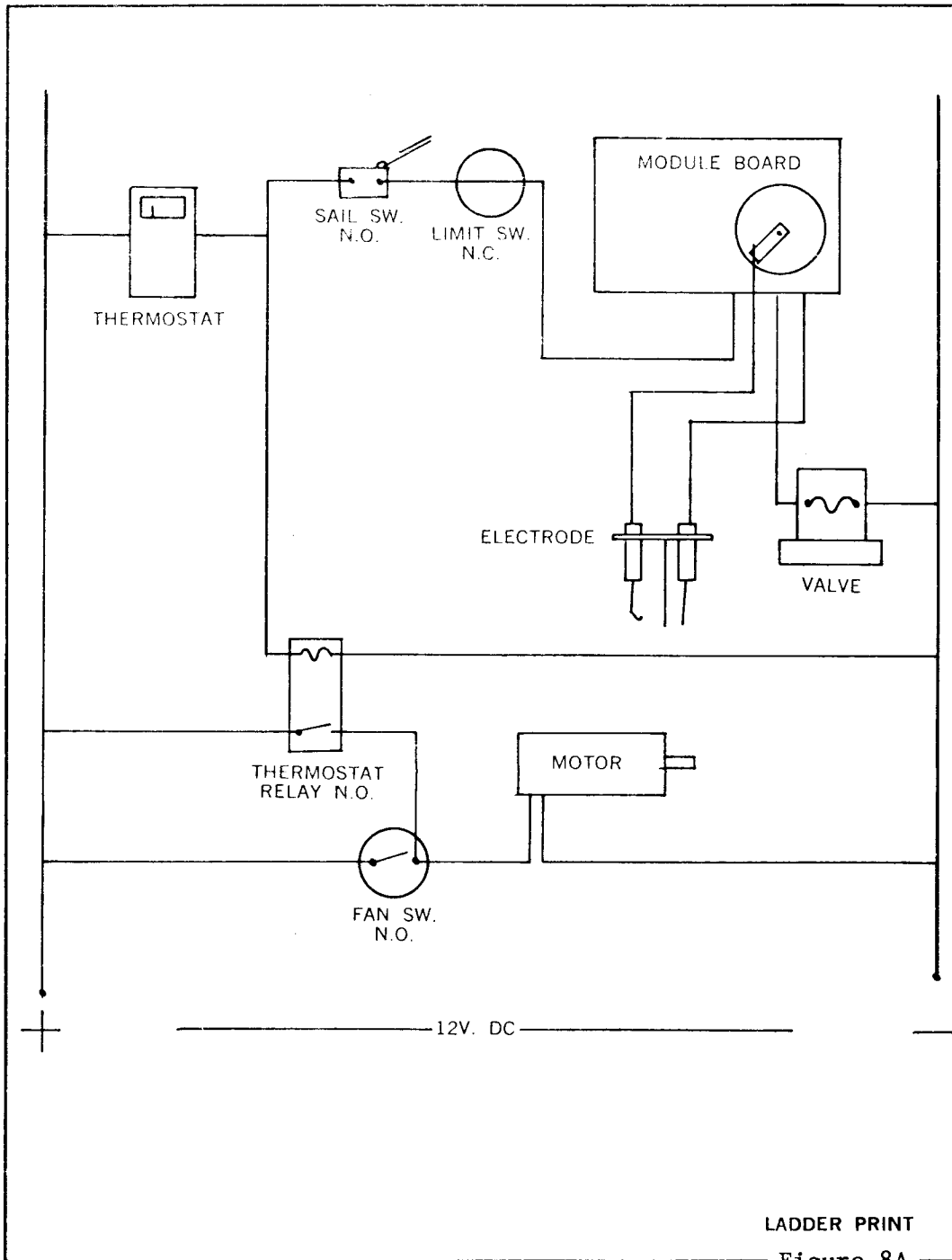

LADDER PRINT

Figure 8A

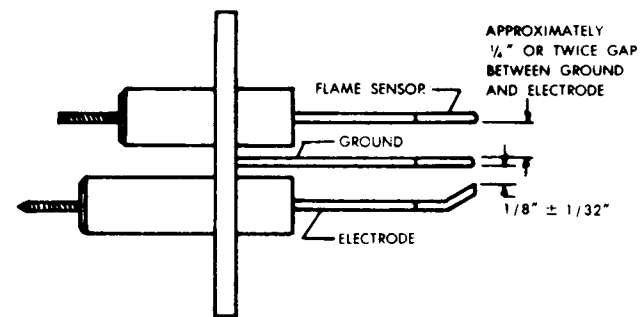

ELECTRODE ASSEMBLY NT-24M & NT-30M

Figure 8

NOTE:
IF ANY OF THE ORIGINAL WIRE
THAT IS SUPPLIED WITH THE
APPLIANCE MUST BE REPLACED,
IT MUST BE REPLACED WITH TYPE
105 C WIRE OR ITS EQUIVALENT.

REPLACEMENT PARTS

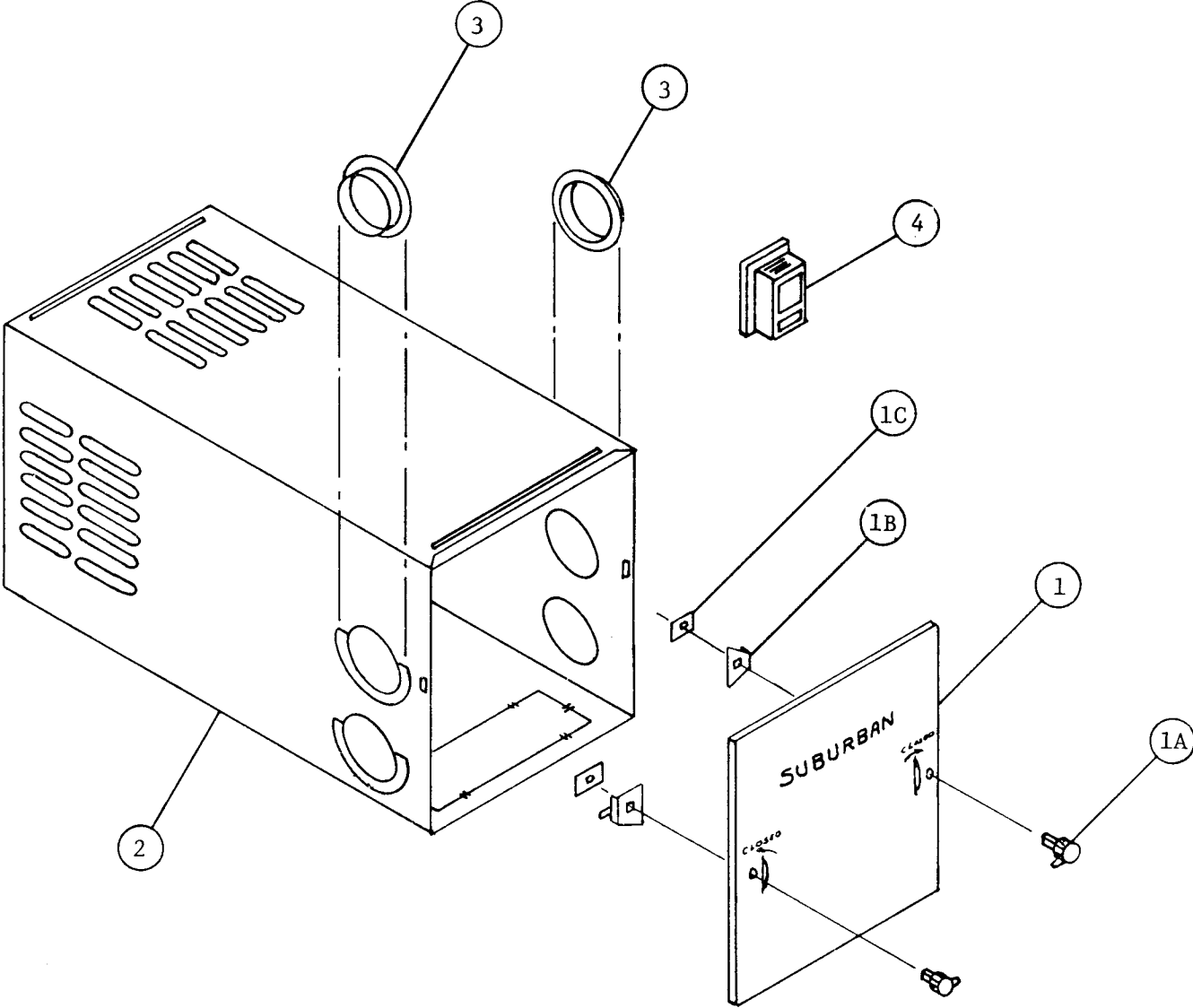

CABINET ASSEMBLY—NT-24M , NT-30M

Figure 9

REPLACEMENT PARTS

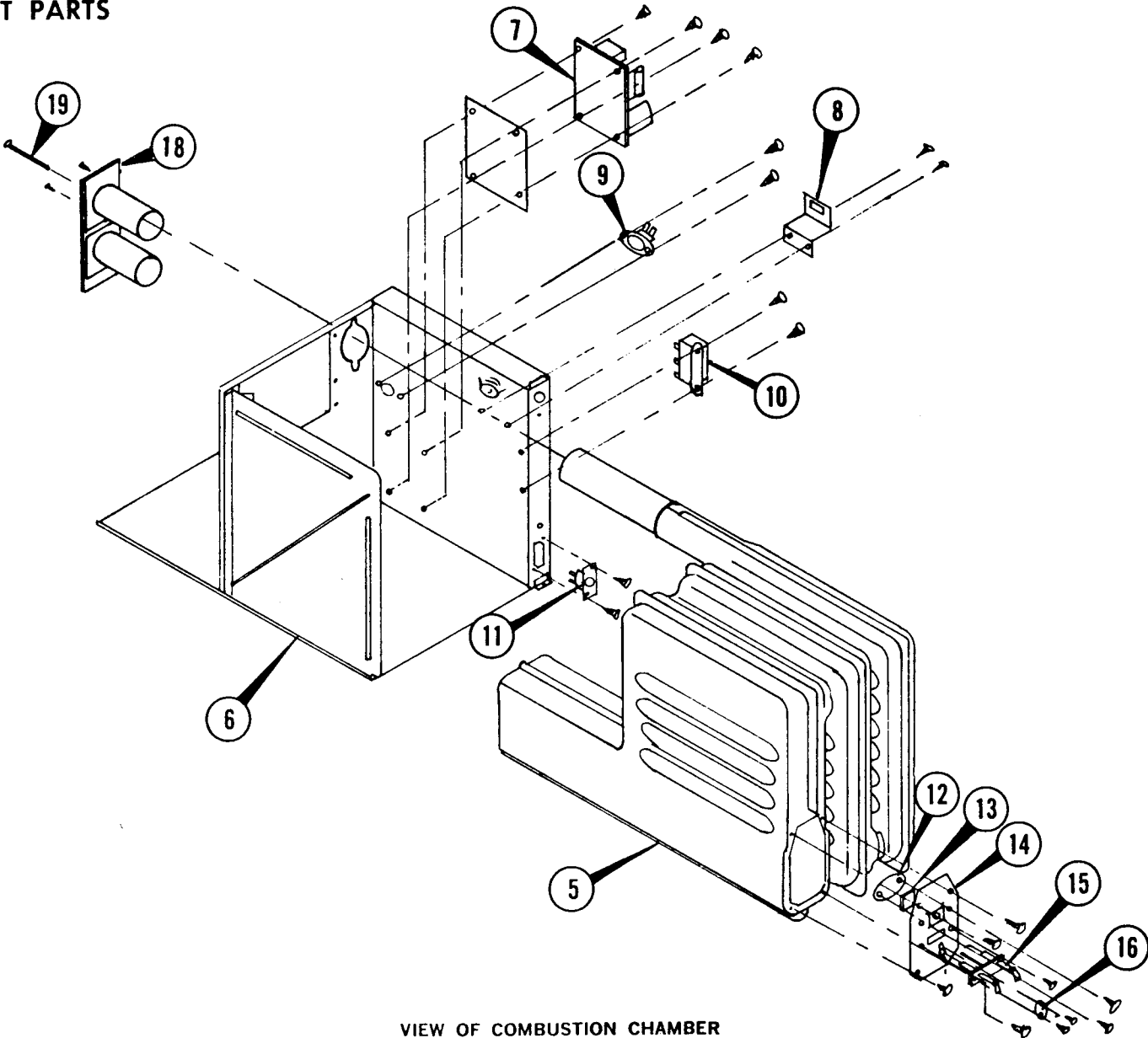

VIEW OF COMBUSTION CHAMBER
ASSEMBLY COMPLETE
NT-24M, NT-30M

Figure 10

REPLACEMENT PARTS

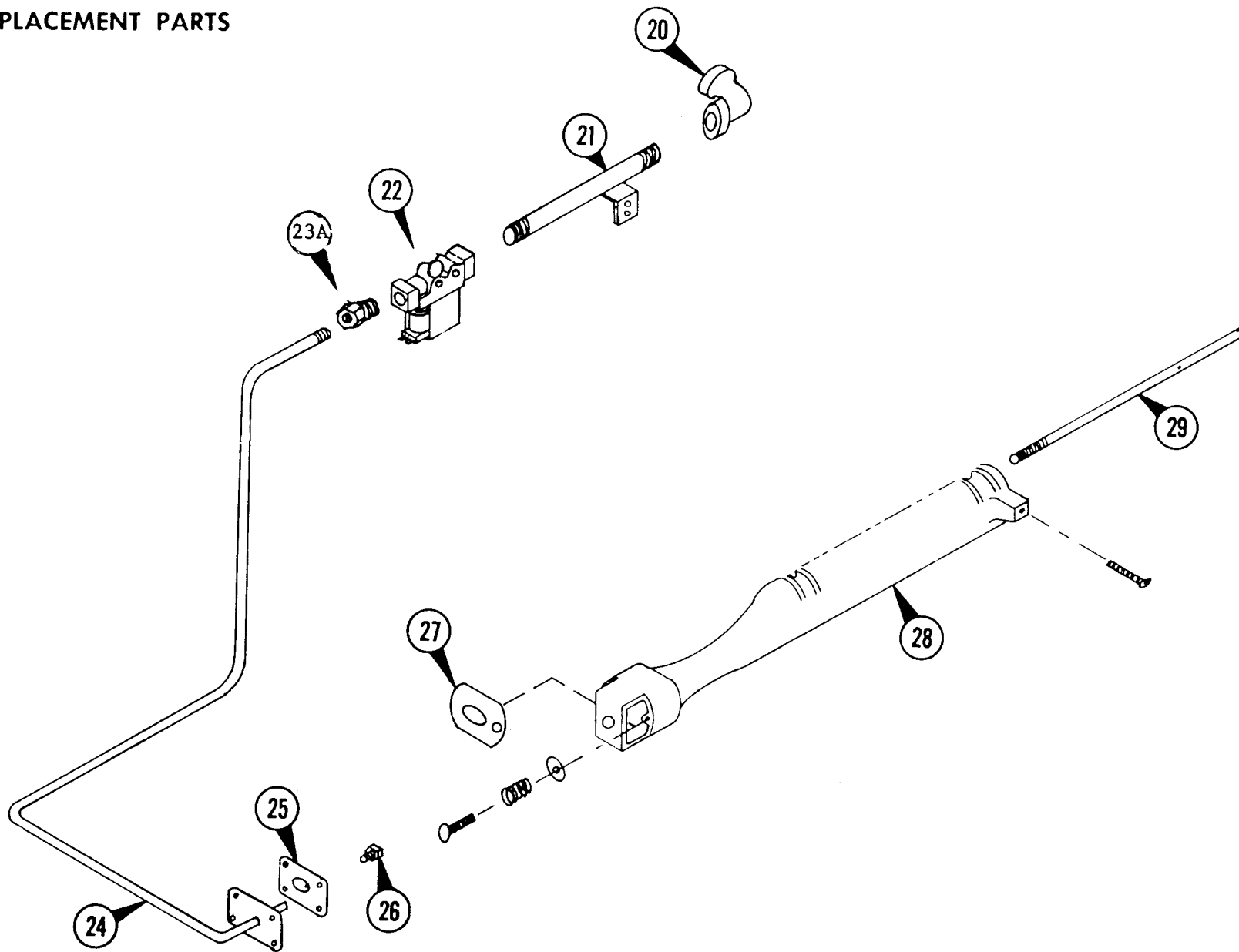

VIEW OF BURNER ASSEMBLY
COMPLETE
NT-24M, NT-30M

Figure 11

REPLACEMENT PARTS

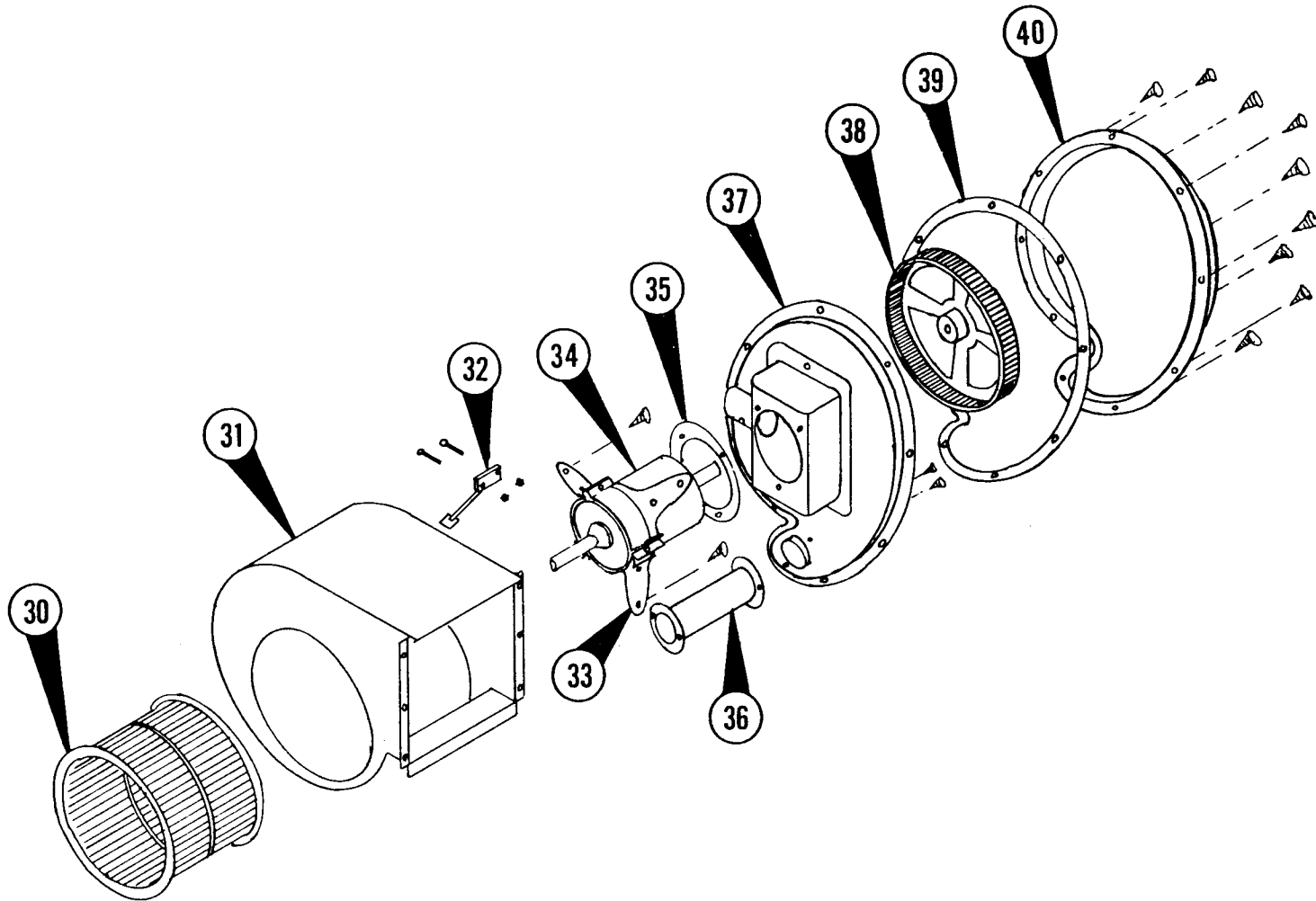

VIEW OF BLOWER ASSEMBLY
COMPLETE
NT-24M, NT-30M

Figure 12

DYNA-TRAIL TRAVEL TRAILER FURNACE
PARTS LIST FOR MODELS
NT-24M and NT-30M

WHEN ORDERING REPAIR PARTS, ALL OF THE FOLLOWING MUST BE GIVEN: COMPLETE MODEL NO.,
CODE NO., SERIAL NO., PART NAME, PART NO. AND NUMBER OF PARTS REQUIRED.
THE FOLLOWING PARTS ARE FOR ALL OF THE ABOVE MODELS UNLESS OTHERWISE SPECIFIED.

Item No.	Description	Part No.	Item No.	Description	Part No.
1	Cabinet Front.....	100861		Orifice, Main Burner	
1A	Knob.....	140149		#52 (NT-30M).....	180214
1B	Latch.....	062230	27	Shutter, Burner Air.....	010582
1C	Nut, Tinnerman.....	121395	28	Burner, Main.....	010581
2	Cabinet Assembly.....	X100859	29	Air Adjustment Rod.....	140146
3	Duct Collar (Round).....	050296	30	Room Air Blower Wheel	
4	Thermostat.....	160737		(Large).....	350076
5	Combustion Chamber.....	X020786	31	Room Air Blower Housing	
6	Radiation Shield Assy...X110319			Assembly.....	X390178
7	Module Board (Fenwal)...230483		32	Microswitch and Paddle	
8	Bracket (PowerSupply)...062135			Assy. (NT-24M).....	X230510
9	Fan Switch.....	230575		Microswitch and Paddle	
10	Relay, Thermostat			Assy. (NT-30M).....	X230509
	RBM-150.....	230423	33	Motor Mount Bracket	
11	Limit Switch.....	230496		(3 Required).....	062138
12	Observation Hole Cover		34	Motor NT-24M.....	230504
	Plate.....	290120		Motor NT-30M.....	230339
13	Observation Glass Disc...310026		35	Motor Mount Gasket.....	070384
14	Combustion Chamber		36	Crossover Tube.....	050439
	Access Door.....	030451	36A	Gasket, Crossover Tube	
14A	Gasket, Access Door			(2 required, not shown)..	070385
	(Not Shown).....	070398	37	Combustion Air Housing	
15	Electrode.....	230495		Assy, Left Half.....	X390179
15A	Electrode Gasket		38	Combustion Air Blower	
	(Not Shown).....	070163		Wheel (small).....	350077
16	Air Adjustment Hole		39	Gasket, Combustion Air	
	Cover.....	290119		Housing.....	070386
16A	Gasket, Air Adjustment		40	Combustion Air Housing	
	Hole (Not Shown).....	070389		(Right Side).....	390173
18	Vent Cap Assembly.....	X260093	41	Rectifier (Diodes) AC/DC	
19	No. 8x3" Sheet Metal			Models Only, 2 req.....	230297
	Screw.....	121249	42	Relay, AC/DC Switching	
20	90° Ell (Black Iron 3/8).170082			AC/DC Models Only.....	230255
21	Gas Inlet Pipe Assy.....	X170494	43	Transformer BE-8912 AC/DC	
22	Valve, Harper-Wyman.....	160762		Models Only, Not Shown...	230323
23A	Fitting, Reducer.....	160545	44	Valve, Manual Shutoff	
24	Manifold Pipe Assy.....	X170537		(Not Shown).....	160740
25	Gasket, Manifold Pipe....070408				
26	Orifice, Main Burner				
	#54 (NT-24M).....	180215			

LIMITED WARRANTY

RECREATIONAL VEHICLE HEATING UNIT

Suburban Manufacturing Company ("Suburban") warrants to the first purchaser the heating unit against defects in material and workmanship under normal use for a period of one year from date of first purchase of the recreational vehicle. The heat exchanger is warranted to the first purchaser against rustout and burnout for a period of 5 years from date of first purchase of the recreational vehicle. Warranty parts will be replaced at no charge for the parts. Labor will be paid only as set forth in the Service Policy below.

SERVICE POLICY

Suburban Manufacturing Company, with the cooperation of its authorized service centers, will endeavor to assure customer satisfaction. If a defect of material or workmanship in the heating unit is repaired within one year from date of original purchase, Suburban will pay a service allowance to the authorized service center up to the maximum specified under the terms of Suburban's contract with the service center. To obtain repairs or replacements, the owner/user must provide for transportation of the heating unit to and from the service center and must inform the service center of the nature of the defect. A list of authorized service centers is enclosed with Suburban's Installation, Operating and Service Instructions book. The owner/user may obtain an updated list of authorized service centers from Suburban Manufacturing Company at any time. All repairs made after one year from date of original purchase will be at the expense of the owner/user.

EXCLUSIONS AND LIMITATIONS

- A. There are no other express warranties except as set out above, and any implied warranties are limited in duration to one year from date of first purchase of the recreational vehicle. Some states do not allow limitations on how long an implied warranty lasts, so the above limitation may not apply to you.
- B. This limited warranty excludes consequential damages, incidental damages, or incidental expenses, including damage to property. Some states do not allow the exclusion or limitation of incidental or consequential damages, so the above limitation or exclusion may not apply to you.
- C. This limited warranty does not cover damages caused by improper installation, mishandling, neglect, abuse, improper energy supply, other circumstances beyond Suburban's control such as fire, flood or other acts of God, or operation of the heating unit contrary to the provisions of the Installation, Operating and Service Instructions book of Suburban or contrary to proper voltage and fuel ratings as design certified by the American Gas Association.
- D. Certain services are not included under the service policy. They are:
 1. Initial checkout and subsequent checkouts which determine that the furnace is operating properly.
 2. Cleaning.
 3. Water or dirt in controls, fuel lines, and gas tanks.
 4. Broken or shorted wires.
 5. Restriction or alteration of warm air or return air circulation.
 6. Thermostat adjustments.
 7. Instructing owners in operation.
 8. Adjusting primary air.
 9. Pilot adjustment.
 10. Electrode adjustments.
 11. Clogged orifice.
 12. Disconnected wires.
 13. Broken parts.

WARRANTY NOTICE

This warranty has been drafted to comply with new federal law applicable to products manufactured after July 4, 1975. It replaces any warranty included elsewhere in this package.

This warranty gives you specific legal rights and you may also have other rights which vary from state to state.



SUBURBAN MANUFACTURING COMPANY
Dayton, Tennessee 37321