



**1976**

**TRANSMODE**

# **OPERATING MANUAL**

**MODELS ZEO6083 AND ZEO6583**

**IMPORTANT OPERATING, SAFETY AND MAINTENANCE INSTRUCTIONS**



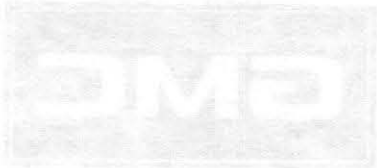

## A WORD TO GMC OWNERS . . .

This manual has been prepared to acquaint you with the operation and maintenance of only the chassis and body components of your TransMode Vehicle, and to provide important safety information. It is supplemented by convenient folders which provide additional information on vehicle maintenance, emission control, and warranties. We urge you to read these publications carefully and follow the recommendations to help assure the most enjoyable and troublefree operation of your vehicle.

When it comes to service, remember that your GMC MotorHome dealer knows your chassis and body components best and is interested in your complete satisfaction. Return to him for Guardian Maintenance Service and any other assistance you may require.

GMC Truck and Coach maintains a number of Zone Offices throughout the country. Should you have a problem that cannot be handled through normal channels, follow the procedure presented in Section 6 of this manual under the heading, "Owner Assistance".

We would like to take this opportunity to thank you for choosing a GMC product—and assure you of our continuing interest in your motoring pleasure and satisfaction.

GMC Truck & Coach Division

FOR CONTINUING SATISFACTION, KEEP YOUR VEHICLE  
ALL GM. GENERAL MOTORS PARTS ARE IDENTIFIED BY  
ONE OF THESE TRADEMARKS:



IMPORTANT OPERATING SAFETY AND MAINTENANCE INSTRUCTIONS



# GMC TRANSMODE VEHICLE

## Operating Manual

This manual should be considered a permanent part of the vehicle, and must remain with the vehicle at time of resale.

For vehicles sold in Canada, substitute the name General Motors of Canada Limited, wherever the name GMC Truck and Coach Division appears in this manual.

*All information, illustrations and specifications contained in this manual are based on the latest product information available at the time of publication. The right is reserved to make changes at any time without notice.*

GMC Truck & Coach Division  
General Motors Corporation  
Pontiac, Michigan 48053

### TABLE OF CONTENTS

Section	Page
1 Before Starting Your Vehicle . . . . .	5
2 Starting and Operating Vehicle . . . . .	10
Steering Column Controls . . . . .	12
Floor Controls . . . . .	17
Instrument Panel and Controls . . . . .	19
3 In Case of Emergency . . . . .	33
4 Appearance Care . . . . .	39
5 Service and Maintenance . . . . .	45
6 Specifications, Owner Assistance, Index, Gas Station Information	67

# IMPORTANT INFORMATION ON VEHICLE LOADING

## OVERLOADING

### CAUTION

The components of your vehicle are designed to provide satisfactory service if the vehicle is not loaded in excess of either the Gross Vehicle Weight Rating (GVWR) or the maximum Front and Rear Gross Axle Weight Ratings (GAWR's) specified on the vehicle identification number (VIN) plate located behind the right front access door. Overloading can create serious potential safety hazards and can also shorten the service life of your vehicle. Your dealer can advise you concerning proper loading conditions of your vehicle.

## MAXIMUM FRONT AND REAR AXLE WEIGHTS (AS MANUFACTURED)

The weight of the cargo load must be properly distributed over both the front and rear axles, although not necessarily evenly. The (VIN) plate shows the maximum weight that the front axle can carry (front GAWR) and the maximum weight that the rear axle (rear GAWR) can carry. The GVWR represents the maximum permissible loaded weight of the vehicle and takes into consideration the engine, transmission, frame, brake, axle and tire capabilities. Actual front and rear end weights at the ground can only be determined by weighing the vehicle. This can be accomplished through highway weigh stations or other such commercial facilities. For assistance in this regard, consult your

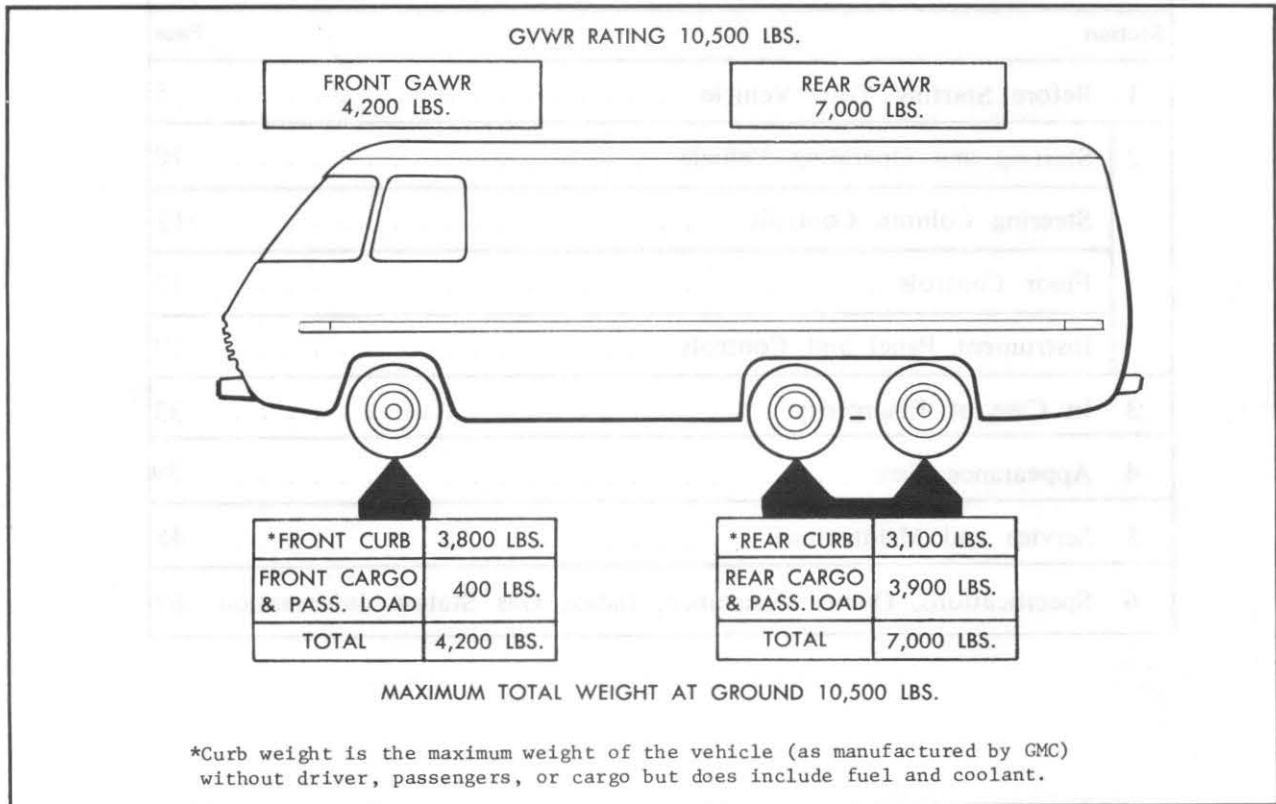

*Vehicle Loading (23' Model)*

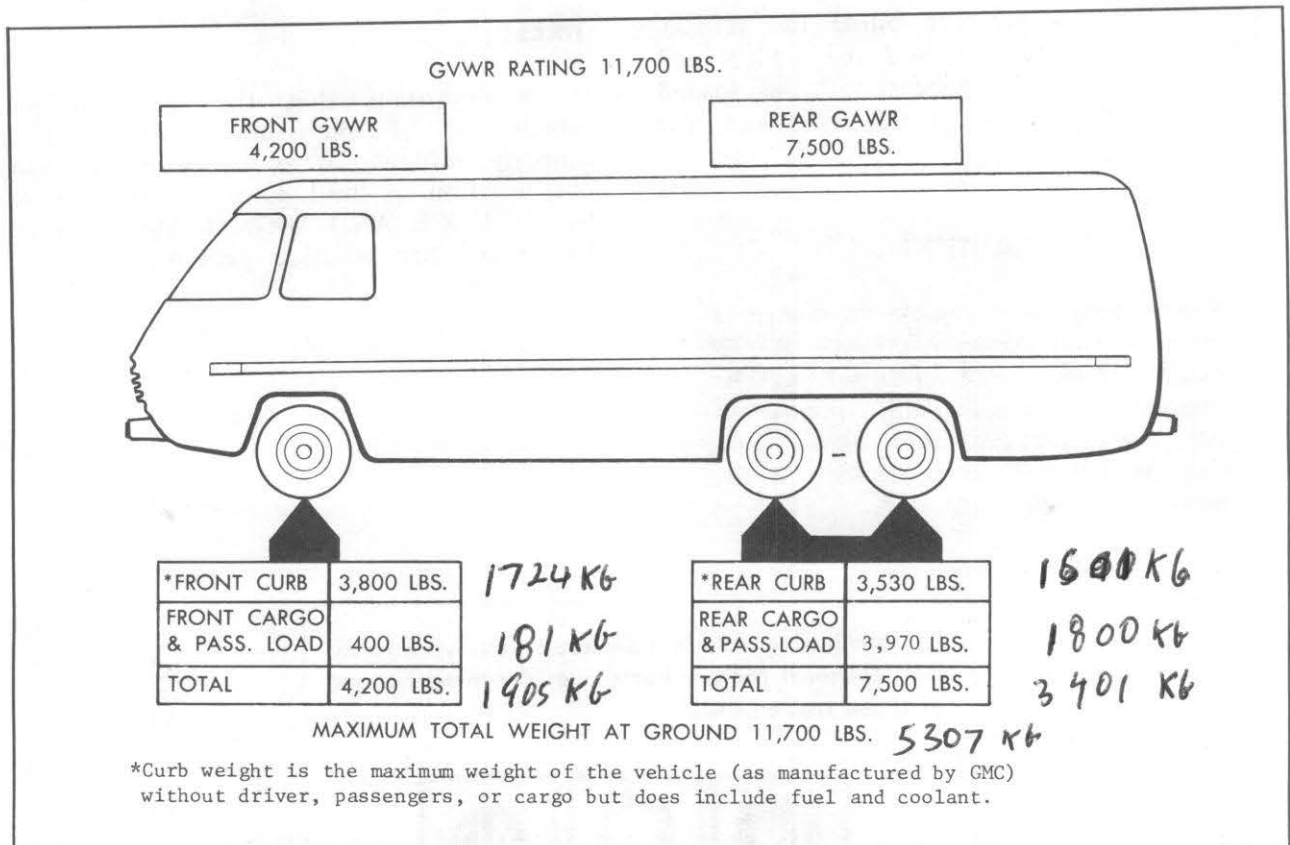

### Vehicle Loading (26' Model)

dealer. Care should also be exercised to see that the cargoload is distributed on both sides of the centerline of the vehicle as equally as possible.

#### EFFECT ON WARRANTY

Your New Vehicle Warranty does not apply to any part of your vehicle "which has been subject to misuse." Any part which fails because of overloading has been subject to misuse.

#### ALLOWABLE LATERAL WEIGHT VARIATION

The independent suspension on this vehicle could be adversely affected by an unbalanced load on either side of vehicle. The allowable front lateral weight variation is 250 pounds. The allowable rear lateral weight variation is 600 pounds.

#### VIN (Vehicle Identification Number) Plate

The vehicle identification number plate shows the GVWR and the front and rear GAWR's for the vehicle to which they are attached.

Gross Vehicle Weight (GVW) is the weight of the vehicle itself, all items added to the vehicle after it has left the factory, the driver and all occupants, and everything

**○ GENERAL MOTORS CORPORATION ○**

WARRANTY MAY BE VOIDED IF WEIGHT EXCEEDS ANY OF RATINGS SHOWN. GROSS VEHICLE WEIGHT INCLUDES WEIGHT OF BASE VEHICLE, ALL ADDED EQUIPMENT, DRIVER AND PASSENGERS, AND ALL PROPERTY LOADED INTO OR ONTO VEHICLE.

RATINGS IN POUNDS - AS MANUFACTURED

GROSS VEHICLE WEIGHT FOR THIS VEHICLE

MAXIMUM FRONT END WEIGHT AT GROUND

MAXIMUM REAR END WEIGHT AT GROUND

VEHICLE IDENTIFICATION NO.

*Vehicle Identification Plate*

that is loaded into (or onto) the vehicle. *The GVW must not exceed the GVWR* and the front and rear weights of the loaded vehicle must not exceed the front and rear GAWR's.

### CAUTION

When using your vehicle to transport luggage or other cargo, it is recommended that the articles be secured in place. This precaution will help prevent such items from becoming dangerous projectiles in the event of an accident.

### TIRES

It is important that the tires on your vehicle be of the proper size, and be properly inflated. It is important to avoid over-inflation as well as under-inflation. See the SERVICE AND MAINTENANCE section for proper tire inflation pressures.

For continuing satisfaction keep your vehicle all GM. General Motors Parts are identified by one of these trademarks:



## SECTION 1

# BEFORE STARTING YOUR VEHICLE

### DRIVER CHECKLIST

#### Before Entering Vehicle

1. See that windows, mirrors and lights are clean.
2. Visually note inflation condition of tires.
3. Check that area to rear is clear if about to back up.

#### Before Driving Off

1. Lock all doors.
2. Position seat.
3. Adjust inside and outside mirrors.
4. Fasten seat belts.
5. Check that warning bulbs light when key is turned to start position.
6. Release parking brake (and see that brake warning light turns off).
7. Be sure you understand your vehicle and how to operate it safely.

**REMINDER:** Always lock entrance door when driving for greater security in the event of an accident, to help keep children from opening door, and for greater security against entry by unwelcome persons while momentarily stopped.

### INSIDE REARVIEW MIRROR

Switch inside mirror to night position to reduce glare from following headlights.

To raise or lower mirror to achieve desired field of view, grasp mirror and exert sufficient pressure by pushing or pulling up, down, or sideways.

### KEYS

Two sets of keys are furnished with your vehicle. Each key has a different cross section so that it can be inserted only in certain locks.

*Key with Square Head*—For ignition switch only.

*Key with Oval Head*—For door lock, glove box and other locking compartments.

The code number of each key is stamped on the “knock out” plug in the key head. Your dealer removed these plugs and placed them with the spare set of keys in the special key envelope that was given to you at the time of delivery. For your protection:

- Record the numbers on the key envelope and discard the key plugs.
- Keep the key envelope in a safe place such as your wallet, NOT IN THE VEHICLE.

In the event the original keys are lost, duplicates can be made by your dealer or

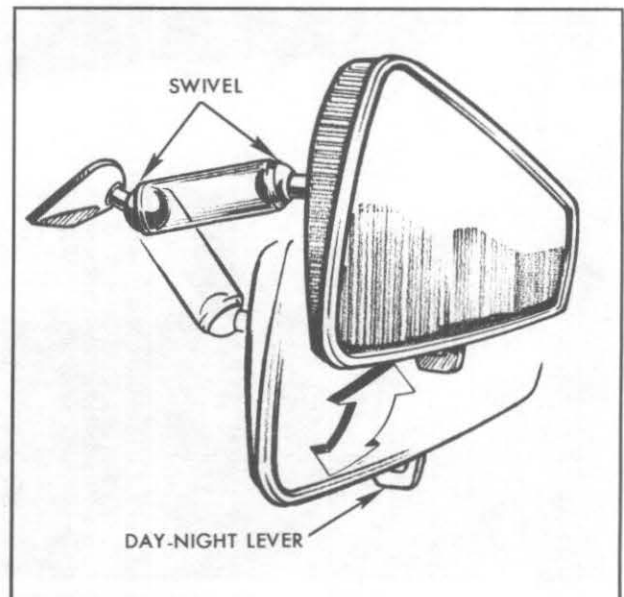

*Inside Rearview Mirror*

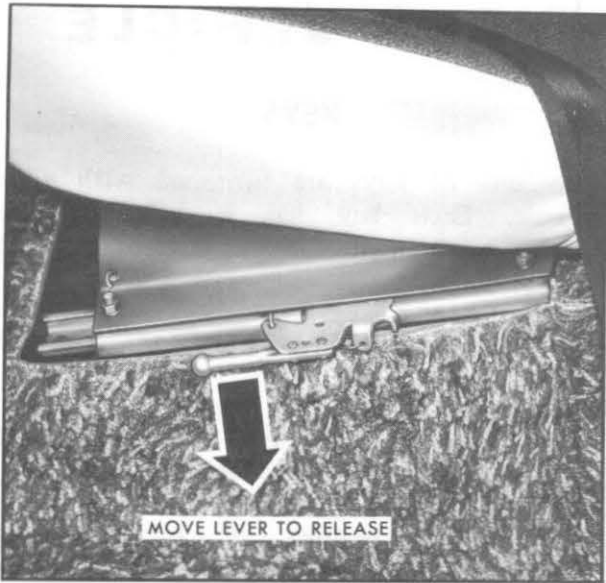

*Seat Track Mechanism*

a locksmith using the key code information.

Be sure to lock the glove box and remove the key from the vehicle whenever it is necessary to leave the ignition key with an attendant.

## SEATS

The driver and passenger seats in the driver compartment may be adjusted to

suit an individual's preference (except dual passenger seat). To move seat forward or backward, simply release the seat locking lever located on the left side of the seat. Once released, exert slight body pressure in the direction desired. Release lever to lock the seat in the desired position.

The seats can be swiveled to provide easy entrance and exit. To turn swivel seat, release locking mechanism by moving seat swivel lever, then turn seat.

### CAUTION

After adjusting a manually operated seat, always use body weight to push forward and backward on seat to twist seat to assure that seat adjusters and swivel lock have securely engaged in the new position. Motion of the seat indicates that latches are not properly engaging. If the seat is not locked in position, the chance of injury and/or the severity of injury in the event of an accident could increase. If this condition persists, take the vehicle to your dealer for service. DO NOT adjust the driver's seat swivel or fore and aft mechanism while the vehicle is moving. The seat could move unexpectedly causing loss of control of the vehicle.

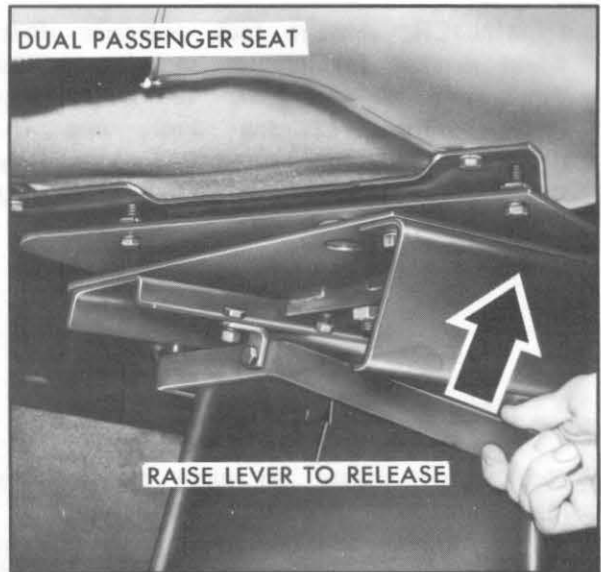
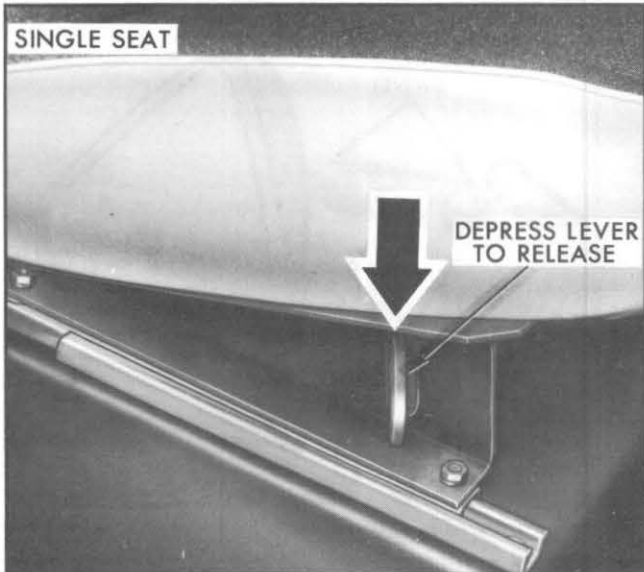

*Seat Swivel Mechanism*



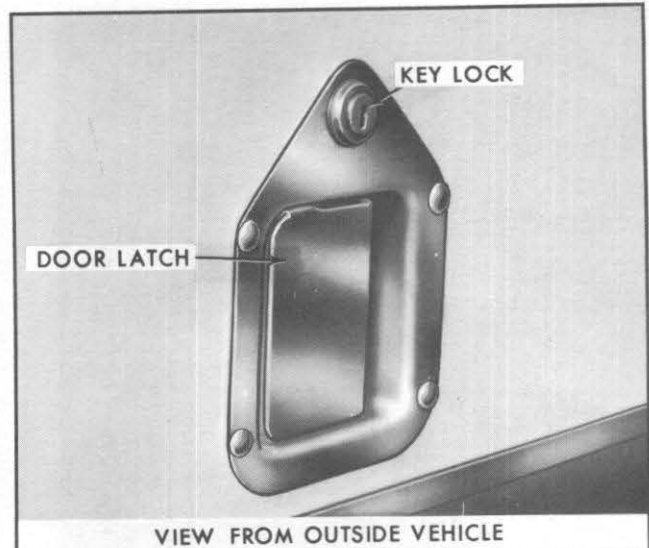
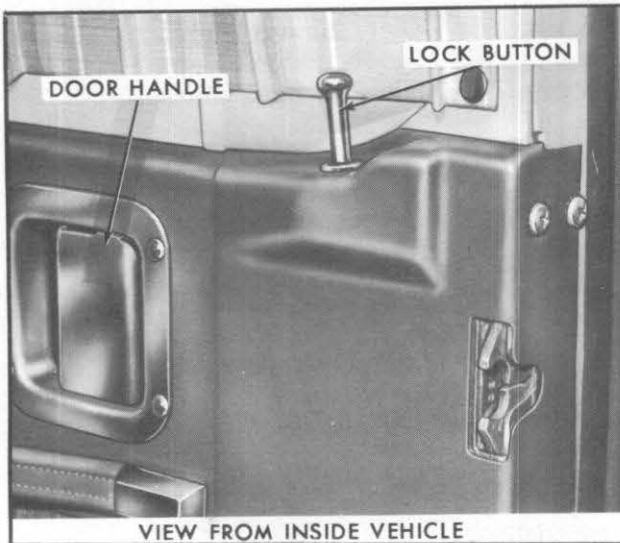

*Entrance Door Latch*

## ENTRANCE DOOR

### DOOR LATCH

Door must be locked from outside the vehicle by inserting the key into the door key lock and turning. To unlock, turn in the clockwise direction. Reverse the direction to lock.

To lock door from inside vehicle, push the lock button **DOWN**. To unlock and open door from the inside, pull the lock button **UP** and pull on inside door handle.

### LAP BELTS

Your vehicle is equipped with lap belts in the driver and front passenger seating position(s). It is recommended that while the vehicle is in motion, all occupants remain seated and keep lap belts buckled snugly at all times.

**The front outboard seating positions**—have retractors which are designed to automatically take up excess webbing.

- Adjust seat to your satisfaction and sit erect and well back in the seat.
- In a single motion, pull webbing across lap far enough to permit inserting metal latch plate end of lap belt into the buckle, until a snap is heard. If webbing

is not pulled out far enough to reach the buckle, let the belt rewind into the retractor to release lock mechanism, so belt can be pulled out to the proper length.

- Position lap belt across lap as **LOW ON HIPS** as possible. To reduce the risk of sliding under the belt during an accident, adjust to a **SNUG FIT** by pulling belt firmly across lap in direction of retractor so it can take up slack.

**NOTE:** Take care not to let the lap belt twist while it is being rewound into the retractor. The bulk of the twisted belt may cause the retractor to jam so it will not rewind further, while at the same time the retractor's locking mechanism may prevent the belt from being withdrawn. If a belt should become jammed, you may be able to release it by working the belt in or out until the belt rewinds far enough to unlock. If lap belt remains jammed or other parts of the restraint system do not operate properly take the vehicle to your dealer for service.

### CAUTION

A snug fit and a low lap belt position are essential to lessen the chance of injury in the event of an accident, because this spreads the

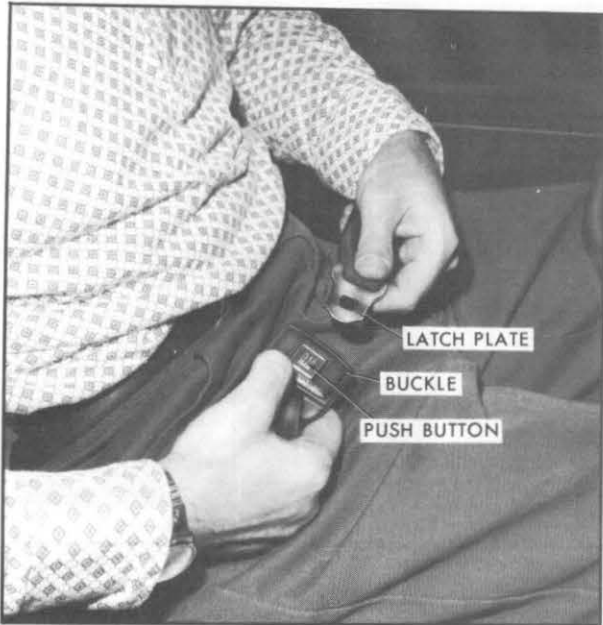

*Lap Belt (Front Seating Position)*

force exerted by the lap belt in a collision over the strong hip bone structure rather than across the soft abdominal area. To help lessen the chance of injury in the event of an accident: Never use the same belt for more than one person at a time; avoid wearing belts in a twisted condition; do not allow belts or hardware to become damaged by being pinched between the seat structural (metallic) members or in the door.

Inboard seating position, front dual passenger seat (if so equipped)—should be positioned and secured as above, and adjusted to a SNUG FIT by pulling on the end of the belt extending from the adjustable latch plate.

- To lengthen the lap belts at these seating positions, place adjustable latch plate at right angle to the belt webbing and pull on latch plate; belt should then slide easily through the adjustment feature.
- To unfasten seat belts, depress push button in center of buckle.

- When no longer in use, front outboard lap belts can be stowed by allowing them to rewind into their retractors.

## LAP BELT INSPECTION

- Periodically inspect belts, buckles, latch plates, retractors, and anchors for damage that could lessen the effectiveness of the restraint system.
- Keep sharp edges and damaging objects away from belts and other parts of the restraint system.
- Replace belts if cut, weakened, frayed, or subjected to collision loads.
- Check that the anchor mounting bolts are tight.
- Have questionable parts replaced.
- Keep belts clean and dry.
- Clean only with mild soap solution and lukewarm water.
- Do not bleach or dye belts since this may severely weaken them.

## CHILD RESTRAINT

Children in vehicles should be restrained to lessen the risk of injury in accidents, or sudden stops. In using any infant or child restraint system, read and comply with all installation and usage instructions.

All unused lap belts near the child should be stowed properly to help prevent them from striking the child in the event of an accident. Lap belts without storage provisions should have buckles latched and belts adjusted to remove slack.

If a child is traveling in a vehicle not equipped with an appropriate infant or child restraint system, the following precautions should be taken:

1. Infants unable to sit up by themselves should be restrained by placing them in a covered padded bassinet placed crossways in the vehicle (widthwise) on the seat. The bassinet should be securely restrained with the regular vehicle lap belts.

2. Children able to sit up by themselves should be placed on a seat and lap belted. Never allow a child to stand or kneel on any seat or elsewhere in the vehicle, once it is underway.

## TRAILER HAULING

Towing a trailer will affect handling, durability and economy. Maximum safety and satisfaction depends upon proper use of correct equipment and avoiding overloads and other abusive operation.

The maximum loaded trailer weight which you can pull with your vehicle depends on what special equipment has been installed. GMC does not recommend towing any trailer OVER 1,000 POUNDS GROSS TRAILER WEIGHT unless the vehicle HAS THE REQUIRED EQUIPMENT.

To assist in attaining good handling of the Vehicle Trailer Combination, it is important that the trailer tongue load be maintained at approximately 10% of the loaded trailer weight. \*Tongue loads can be adjusted by proper distribution of the load in the trailer, and can be checked by weighing separately the loaded trailer and then the tongue.

The allowable passenger and cargo load (GVW) of this vehicle is reduced by an amount equal to the trailer tongue load on the trailer hitch.

### CAUTIONS

1. Trailer brakes are required on trailers over 1,000 lbs. loaded weight.
2. DO NOT tap into vehicle's hydraulic brake system if operation of the trailer brake system requires more than 0.02 cu.-in. of fluid displacement from the vehicle's master cylinder. The vehicle's master cylinder fluid capacity will not be sufficient to operate both vehicle and trailer brakes under all conditions of use if more than 0.02 cu.-in. of fluid displacement is required.

3. Whenever a trailer hitch is removed, be certain to have any mounting holes in underbody properly sealed to prevent possible entry of exhaust fumes, dirt or water. (See "ENGINE EXHAUST GAS CAUTION" in the following section.)

## OPERATION IN FOREIGN COUNTRIES

Your vehicle's engine is designed to operate on unleaded fuel of approximately 91 research octane number.

If you plan to operate your vehicle outside the continental limits of the United States or Canada, there is a possibility that the best fuels available are so low in anti-knock quality that excessive knocking and serious engine damage may result from their use. To obtain information on the quality of fuels available in the countries in which you plan to travel write to GMC Truck & Coach Division, General Motors Corporation, Pontiac, Michigan 48053 (or in Canada write to General Motors of Canada Limited, Owner Relations Department, Oshawa, Ontario), giving:

- The vehicle identification number (from plate attached to right side of dash panel or from the registration slip or title).
- The country or countries in which you plan to travel.

It is recommended that you do not operate your vehicle in any country not having fuels meeting the requirements of your vehicle's engine as these MAY CAUSE ENGINE DAMAGE for which GMC Truck & Coach is not responsible under the terms of the New Vehicle Warranty or Emission Control Systems Warranty.

## SECTION 2

# STARTING AND OPERATING VEHICLE

### ENGINE EXHAUST GAS CAUTION (CARBON MONOXIDE)

Avoid inhaling exhaust gases because they contain carbon monoxide, which by itself is colorless and odorless. Carbon monoxide is a dangerous gas that can cause unconsciousness and is potentially lethal.

If, at any time, you suspect that exhaust fumes are entering the vehicle from any source have the cause determined and corrected as soon as possible. If you must drive before the cause is corrected, drive only with ALL windows FULLY open and heating or cooling system adjusted for maximum ventilation (see below).

The best protection against carbon monoxide entry into the vehicle body is a properly maintained engine exhaust system, body and body ventilation system. It is recommended that the exhaust system and body be inspected by a competent mechanic:

- Each time the vehicle is raised for lubrication or oil change.
- Whenever a change is noticed in the sound, alignment, or appearance of the exhaust system.
- Whenever the exhaust system, underbody or rear of the vehicle is damaged.

See your Maintenance Schedule folder for inspection procedure.

To allow proper operation of the vehicle's ventilation system, keep front inlet grille clear of snow, leaves, or other obstructions at all times.

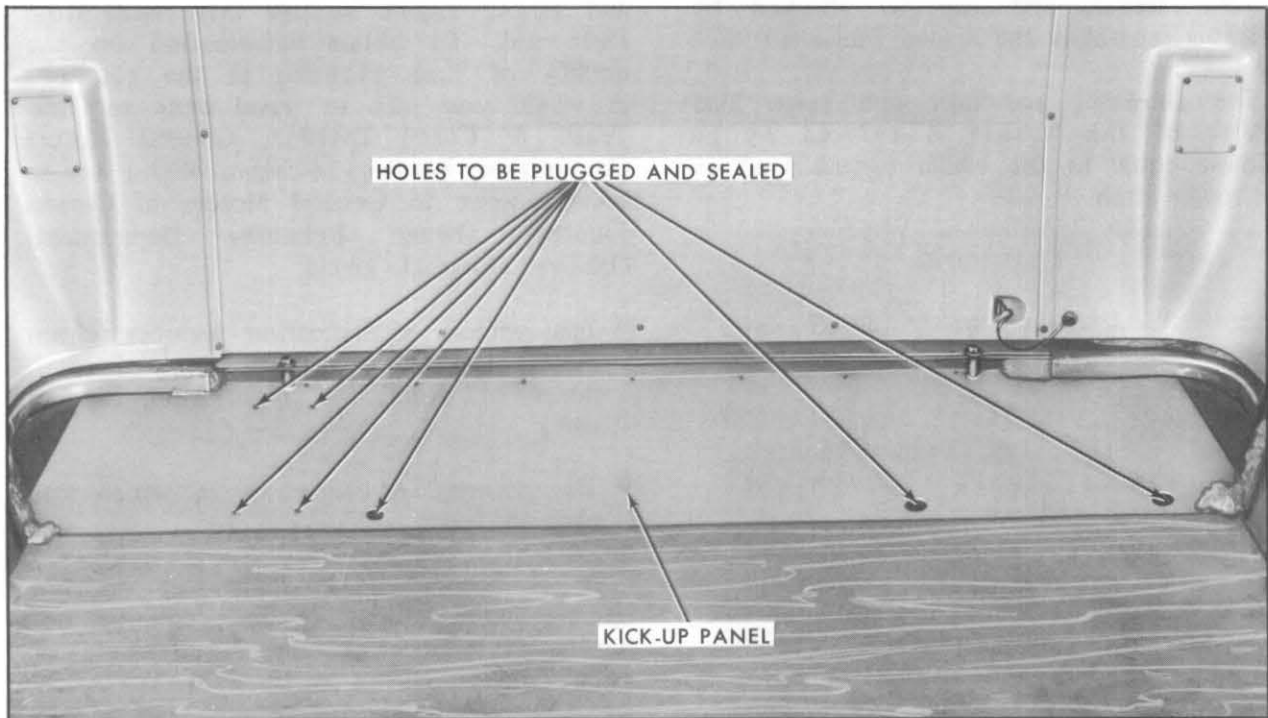

*Location of Holes in Kick-up Panel*

**OCCUPYING A PARKED VEHICLE WITH ENGINE RUNNING FOR AN EXTENDED PERIOD OF TIME IS NOT RECOMMENDED.**

Do not run engine in confined areas such as garages any more than needed to move vehicle in or out of area. When vehicle is stopped in an UNCONFINED area with the engine running for any more than a short period of time, adjust heating or cooling system to force outside air into the vehicle as follows:

1. On vehicles not equipped with automotive air conditioning, set fan to medium or high speed and upper control lever to any position except "OFF."
2. On vehicles equipped with automotive Air Conditioning, set fan to medium or high speed and upper control lever to any position except "OFF".

The two rear windows (if so equipped) should be closed while driving to avoid drawing dangerous exhaust gases into the vehicle through those openings. In addition, it is recommended that roof vent(s) be closed while driving. If, for some reason, a rear window or roof vent must remain open for a period while driving, or electrical wiring or other cable connections to a trailer must pass through the seal between them and the body, the following precautions should be observed.

- Close all windows.
- Adjust heating or cooling system to force outside air into the vehicle as described in Step 1 or 2 above but with fan set at high speed.
- Air vents in or under the instrument panel should be fully open.

It is important that the inside engine cover be properly seated to prevent possible leakage of exhaust fumes into the vehicle through this opening.

The kick-up panel at the rear of the floor (see illustration) contains holes which may be utilized to facilitate access to the interior for installation of certain interior equipment (i.e., access for wiring, plumbing, etc.) The holes should be plugged and sealed to avoid possible exhaust gas (carbon monoxide) intrusion into the interior of the vehicle.

Whenever operating the optional motor-generator it is essential the left-rear window (if so equipped) of the vehicle be kept closed to prevent possible entry of motor-generator exhaust gases into vehicle. Inspect the motor-generator exhaust system at vehicle lubrication intervals or when a change is noticed in the sound, alignment, or appearance of the exhaust system or if it is damaged. Do not run motor-generator in a confined area, such as a garage.

**NOTE:** Particular care should be taken to prevent the possibility of carbon monoxide exposure when the vehicle is modified for recreational or other usage. Additionally, some recreational vehicle appliances (such as lights, refrigerators, stoves, heaters) may generate carbon monoxide and should be used only if there is adequate ventilation.

# STEERING COLUMN CONTROLS

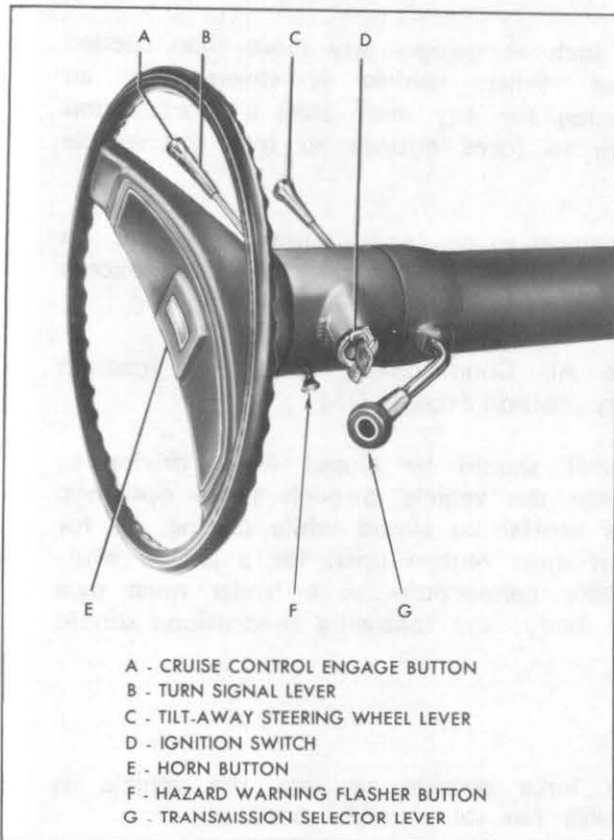

## Steering Column Controls

### ANTI-THEFT STEERING COLUMN LOCK

The anti-theft ignition switch, located on the right side of the steering column, has five positions:

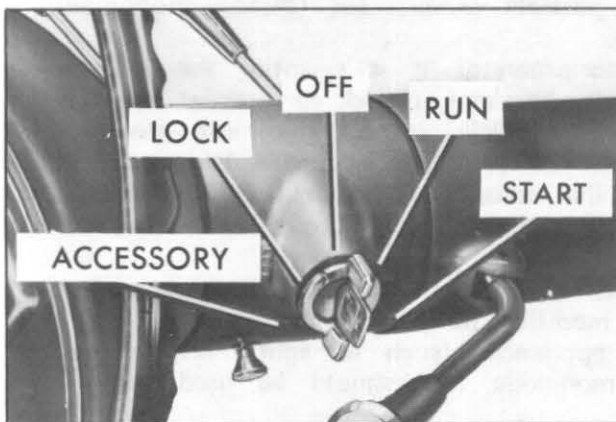

*Anti-Theft Steering Column Lock*

- **ACCESSORY**—Permits operation of electrical accessories when the engine is not running. To engage, push key in and turn toward you (counterclockwise.)
- **LOCK**—Normal parking position, locks ignition and provides added theft protection by preventing normal operation of steering wheel and shift controls. Key cannot be turned to “LOCK” position and removed until transmission is placed in “PARK.”
- **OFF**—Permits turning engine off without locking steering wheel and shift controls.
- **RUN**—Normal operating position.
- **START**—Permits engagement of starter.

**NOTE:** The anti-theft steering column lock is not substitute for the parking brake. Always set the parking brake when leaving the driver’s seat unattended.

If difficulty is experienced in turning the ignition key and lock knob to unlock the ignition, attempt to turn the steering wheel as hard as possible in the direction the wheels are turned. At the same time turn the ignition-lock knob in a clockwise direction with as much effort as you can apply with your own hand. Do not attempt to use a tool of any kind to apply additional force on the lock knob, as this could break the knob.

### PARKING

When leaving the driver’s seat unattended:

- **SET PARKING BRAKE FIRST.** (See note on page 19.)
- Place transmission selector lever in “PARK.”
- Turn key to **LOCK** position.
- Remove key from steering column lock (the buzzer will remind you).
- Lock entrance door if leaving vehicle.

**NOTICE:** Do not leave your vehicle unattended with the engine running. If the engine should overheat while your vehicle is unattended, the temperature warning light or gauge would go unheeded which could result in extensive damage to your vehicle.

## STARTING ENGINE

1. Apply the parking brake.
2. Place the transmission selector in "P" or "N" ("P" is preferred). A starter safety switch is designed to prevent starter operation while the transmission selector is in any drive position. (If it is necessary to re-start the engine with the vehicle moving, place the selector lever in "N".)
3. Depress accelerator pedal and activate starter as outlined in the following, for different conditions.

### COLD ENGINE

Fully depress accelerator pedal and slowly release. With foot off the pedal, crank the engine by turning the ignition key to the "START" position—release when engine starts. If engine starts but fails to run, repeat this procedure. When engine is running smoothly (approx. 30 seconds) the idle speed may be reduced by slightly depressing the accelerator pedal and then slowly releasing.

### CAUTION

Extended running of the engine (5 minutes or more) without depressing the accelerator pedal, could cause damage to the engine or exhaust system due to overheating.

### WARM ENGINE

Depress accelerator pedal about halfway and hold while cranking the engine.

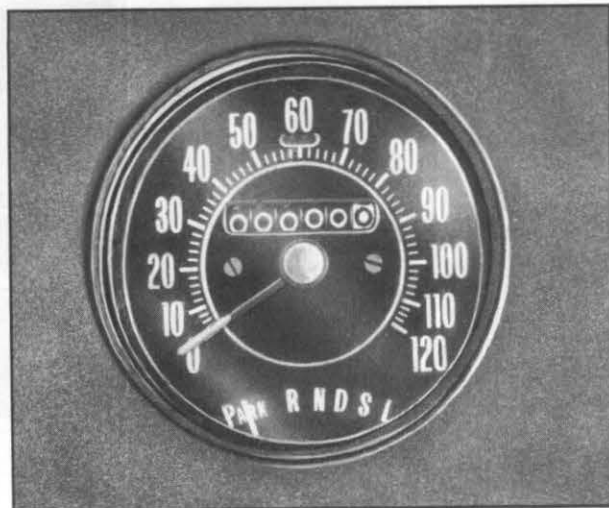

*Transmission Shift Indicator  
and Speedometer*

### EXTREMELY COLD WEATHER (BELOW 0° F.) (-18° C.) OR AFTER VEHICLE HAS BEEN STANDING IDLE FOR SEVERAL DAYS

Fully depress and release accelerator pedal two or three times before cranking the engine. With foot off the accelerator pedal, crank the engine by turning the key to the start position—release key when engine starts.

### IF ENGINE FAILS TO START:

- First, fully depress and release the accelerator pedal several times, then remove foot from accelerator pedal and crank engine.
- If engine still does not start, fully depress the accelerator pedal and hold to the floor while cranking the engine.
- If the engine has been flooded with gasoline, it may start to run but not have enough power to keep running. In this case, continue cranking with the accelerator pedal fully depressed until the engine cleans itself of excess gasoline and runs smoothly.
- If engine doesn't crank properly due to a discharged main battery (automotive battery), place the battery switch in the "BAT BOOST" position. Return the switch to the "BAT NORMAL" position when engine starts.

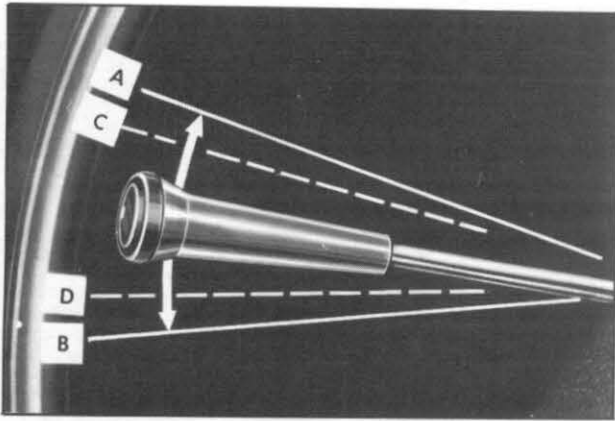

*Turn Signal Lever*

**NOTE:** Do not continue cranking the engine for more than 30 seconds at a time to prevent starter overheating.

### **AUTOMATIC TRANSMISSION**

The transmission selector lever is located on the right side of the steering column and the shift indicator is located in the bottom section of the speedometer cluster on the dash.

- **“PARK”**—Transmission lock when parking or while starting the engine. Pull the selector lever towards you to select or release this position. Never move the selector lever to “PARK” position unless the vehicle is completely stopped. “NEUTRAL” is the only other position in which your vehicle may be started.
- **REVERSE “R”**—For backing the vehicle. Bring the vehicle to a complete stop before moving the selector lever into Reverse.
- **NEUTRAL “N”**—The out-of-gear position. It is provided for starting a stalled engine while the vehicle is in motion or running the engine while standing with brake applied. **DO NOT COAST IN NEUTRAL.**
- **DRIVE RANGE “D”**—The driving range for city and highway driving. This position permits the transmission to operate through its complete range of gear ratios and to select automatically the proper ratio for road and load conditions.

- **SUPER RANGE “S”**—Used when super performance is needed for increased acceleration in traffic, hill climbing, or “Engine Braking” down-hill. The selector lever may be moved from “D” to “S” and vice versa, under most operating conditions. “SUPER” should not be used at speeds above 75 MPH.

- **LOW “L”**—Available for heavy pulling through mud or sand and for engine braking when descending steep hills. The selector lever may be moved to “L” at any speed but the transmission will only shift automatically into Low range when the vehicle speed is under approximately 40 MPH. The transmission will not upshift from Low range as long as the selector lever is in the “L” position.

### **CAUTION**

Before descending a steep or long grade, down a mountain or hillside, reduce speed and shift into a lower gear. Use the lower gear ranges to control vehicle speed. Avoid prolonged or frequent application of the brakes which could cause overheating and thus reduce brake effectiveness. Use caution when shifting into lower range or lower gear on slippery surfaces with vehicle moving—abrupt engine braking action could cause the front wheels to skid, possibly leading to loss of vehicle control.

- **FORCED DOWNSHIFT**—When additional acceleration is desired to pass moving vehicles or to climb steep grades at speeds between approximately 35 and 65 MPH, the transmission can be downshifted by depressing the accelerator pedal completely to the floor. It is also possible to obtain a forced downshift in “DRIVE” range at speeds under 35 MPH by depressing the accelerator pedal part way down.



## TURN SIGNAL AND LANE CHANGE FEATURE

Whenever a right or left turn is intended, when changing lanes, or when pulling away from the curb, use the turn signals.

- **FULL TURN**—For normal turns, move the turn signal lever to position “A” for right turn and “B” for left turn. Lever will remain in position without manual effort until the turn is completed, then cancel automatically.
- **LANE CHANGE**—Move lever to the detent position “C” for change to right lane or to “D” for change to left lane. Hold lever in position until lane maneuver is completed, then release. Lever will return to “OFF” position.

## HAZARD WARNING FLASHER

For operation of hazard warning flasher, see “In Case of Emergency” later in this manual.

## HORN CONTROL

The horn is actuated by depressing the rectangular shaped GMC button located in the center of the steering wheel.

## POWER STEERING

If the steering system power assist fails due to some malfunction, or because the engine has stalled, the vehicle can still be steered. However, much greater effort is required, particularly in sharp turns.

## TILT STEERING WHEEL

The tilt steering wheel can be tilted up above normal position to provide additional room for entrance and exit as well as selected driving positions above or below normal height.

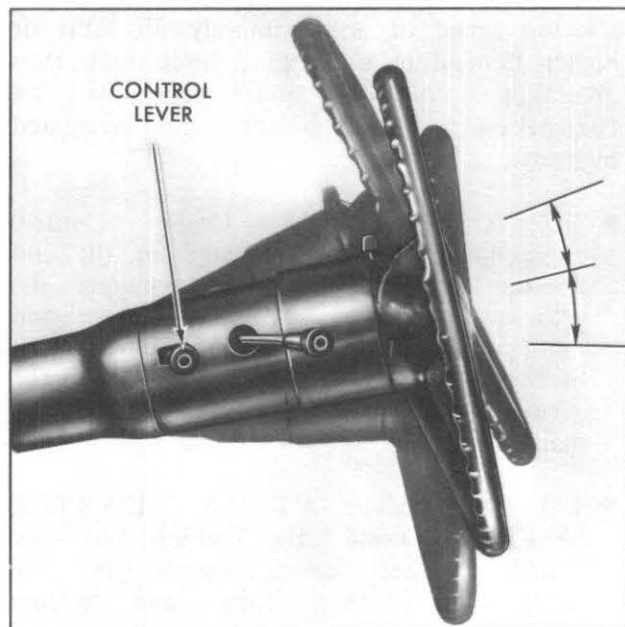

*Tilt Steering Wheel*

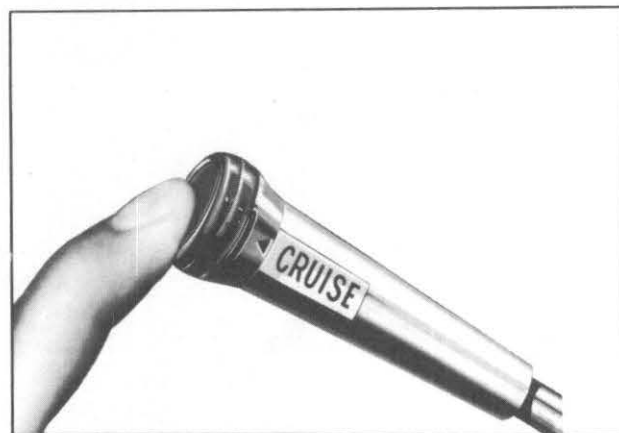

*Cruise Control Lever*

The tilt mechanism is operated by lifting up on the small control lever, on the left side of the steering column just below the directional signal lever, then moving the steering wheel to the selected position and releasing the lever.

## CRUISE CONTROL

The optional Cruise Control is an automatic speed control system which is designed to allow the vehicle to hold a

selected speed of approximately 30 MPH or higher—depending on engine limitations—thus increasing comfort and economy on turnpikes, and other non-congested highways.

- **TO OPERATE**—The Cruise Control engagement button is located in the end of the turn signal lever. Accelerate the vehicle to the desired speed and momentarily push in the engagement button, take your foot off the accelerator and this speed will be maintained.
- **TO RESET AT A FASTER SPEED**—Accelerate the vehicle to the desired higher speed, push in the engagement button fully and release slowly.
- **TO RESET AT A SLOWER SPEED**—Depress the engagement button fully and HOLD. Allow vehicle to

decelerate. When vehicle reaches desired speed, release the engagement button slowly.

- **FOR PASSING**—You can increase your speed by depressing accelerator pedal. When you remove your foot from the pedal, the vehicle will slow down to the cruising speed set prior to the acceleration.
- **TO DISENGAGE**—Lightly apply the brake pedal to disengage system.

### CAUTION

**DO NOT** use the Cruise Control when conditions are not suitable for maintaining a constant speed, such as in heavy or varying traffic, or on winding or slippery roads. With the Cruise Control engaged, removing foot from the accelerator pedal does not permit engine speed to return to idle.

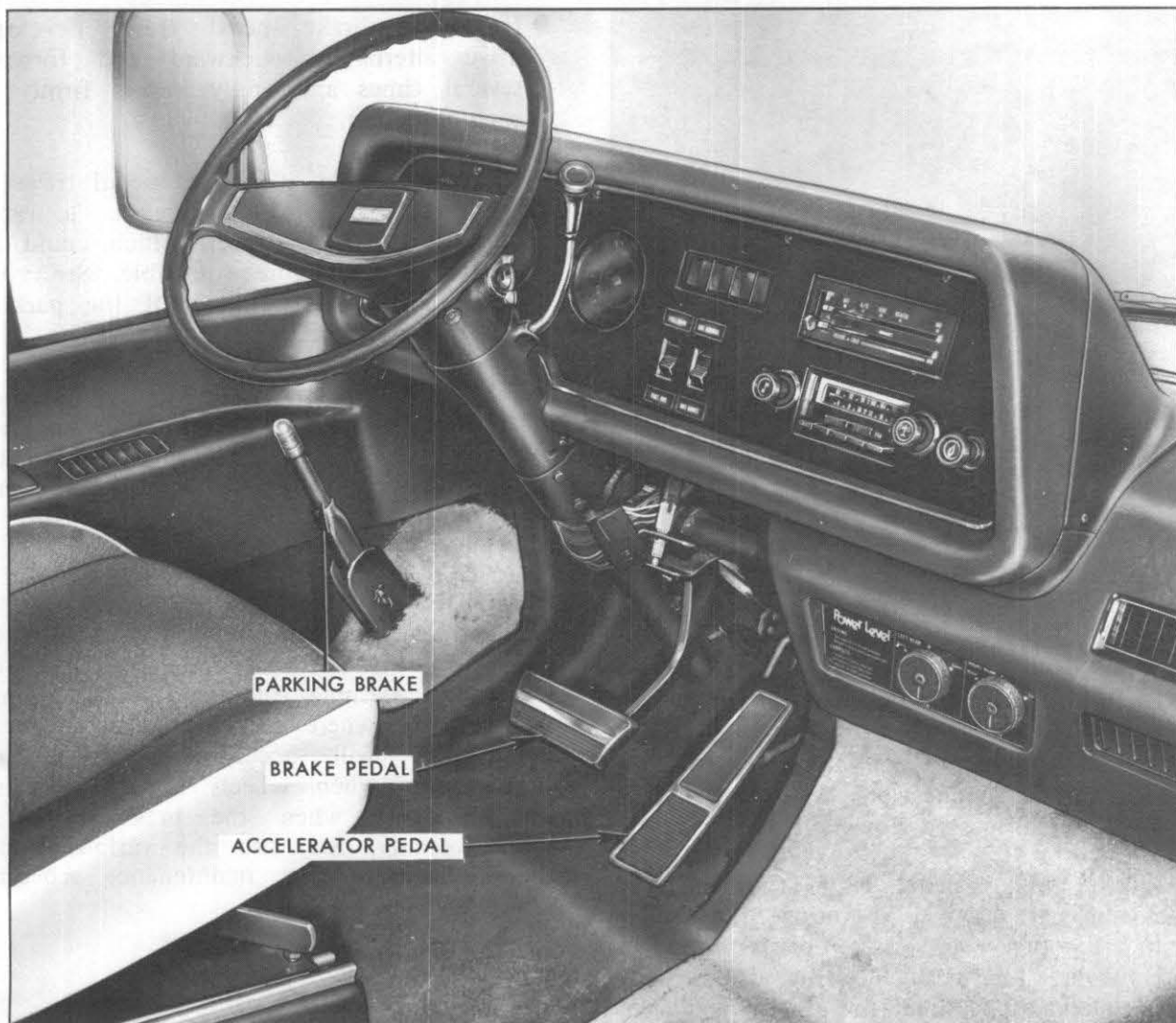

### *Vehicle Floor Controls*

## **FLOOR CONTROLS**

### **POWER BRAKE SYSTEM**

This vehicle is equipped with a Dual Hydraulic Split System With Power Assist. It is also equipped with disc type brakes on the front wheels and drum type brakes on the tandem rear wheels.

**NOTE:** Operation of the brake system warning light is covered (on page 21) (in the section on "Instrument Panel and Controls.")

### **CAUTION**

Driving through deep water may wet the brakes and adversely affect brake performance so that the vehicle will not slow down at the usual rate, and may pull to the right or left. Applying the brakes lightly will indicate whether they have been so affected. To dry them quickly, lightly apply the brakes while maintaining a safe forward speed with an assured clear distance ahead until brake performance returns to normal.

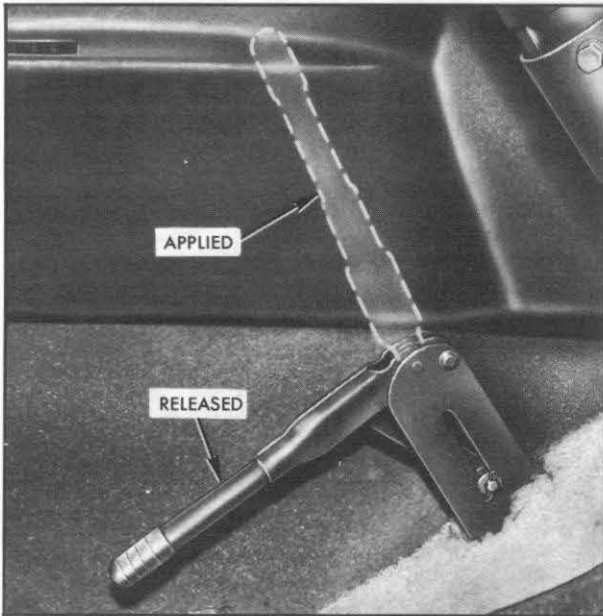

### *Parking Brake Control*

- On your vehicle, if power assist to the brakes is interrupted due to a stalled engine or some malfunction, two or more brake applications can normally be made using reserve power.
- If the brake pedal is held down, the system is designed to bring the vehicle to a full stop on reserve power. However, the reserve power is partially depleted each time the brake pedal is applied and released. Do not pump brakes when brake power assist has been interrupted, except when necessary in order to maintain steering control on slippery surfaces.
- When reserve power is exhausted, the vehicle can still be stopped by applying greater force to the pedal.

### **SELF-ADJUSTING BRAKES**

Brakes on this vehicle (except for the Parking Brake) are self-adjusting, designed to eliminate periodic adjustments.

Drum brake adjustments are made automatically as the brakes are applied while vehicle is moving backwards.

Disc brake adjustment is made automatically with each brake application.

- If excess brake pedal travel develops, drive alternately backward and forward several times and apply brakes firmly in each direction.
- See your dealer if normal pedal travel is not restored, or if there is a rapid increase in pedal travel, which could be a sign of other brake trouble. See your dealer also if adjustment of the parking brake is required.

**NOTE:** "Riding The Brake" by resting your foot on the brake pedal when not intending to brake can cause abnormally high brake temperatures, excessive lining wear and possible damage to brakes in addition to wasting gasoline.

**REMINDER:** Front disc brakes have a built-in wear indicator that is designed to make a high frequency, squealing, or cricket-like warning sound when the linings are worn to where replacement is required. The sound will occur intermittently or continuously when wheels are rolling, but will disappear when the brake pedal is applied firmly. See also the various brake checks listed in the maintenance schedule folder.

### **PARKING BRAKE**

- To set parking brake, pull up the handle located on the floor against the left wall, below the instrument panel.
- For increased holding power, first depress regular brake pedal with the right foot, and hold it while setting the parking brake with left hand.
- To release parking brake push the handle down.
- As a reminder, the "PARK BRAKE" reminder light is designed to come on whenever the parking brake control is not fully released, and the ignition is on.
- Never drive vehicle with parking brake set as this may overheat or otherwise damage rear brakes.

The amount of force required to apply parking brake can be adjusted by turning a tension adjustment knob located at the upper end of the lever. This also adjusts the degree of brake application. The greater the force required at the lever the greater the degree of brake application.

**NOTE:** The parking brake should be set first whenever the driver's seat is left unattended.

If the vehicle is parked on a grade and the transmission is placed in "PARK" before the parking brake is set, the weight of the vehicle may exert so much force on the parking pawl in the transmission that the transmission selector lever cannot later be pulled out of "PARK." To prevent this, the parking brake should be applied BEFORE moving the transmission selector lever to "PARK." When preparing to move the vehicle, the shift indicator should be moved out of the "PARK" position BEFORE releasing the parking brake. It is good driving practice to set the parking brake first, and release the transmission from "PARK" first at all

times, even on the level. If "torque lock", as this condition is called, does occur, it may be necessary to have another vehicle nudge this vehicle up hill, to take some of the pressure off the transmission while the driver pulls on the transmission selector lever.

### HEADLIGHT DIMMER SWITCH

To obtain high or low beam headlights, push the foot dimmer switch located on the floor to the left of the brake pedal. Each time the switch is depressed, the light beam changes. A headlamp beam indicator, on the face of the speedometer, is designed to light up when the headlights are on high beam.

### HEADLIGHT "FLICKER"

The headlight circuits are protected by a circuit breaker in the light switch. An overload on the breaker will cause the lights to "flicker" on and off, or in some cases to remain off. If this condition develops, have your headlight electrical circuit checked immediately.

## INSTRUMENT PANEL AND CONTROLS

### SPEEDOMETER AND ODOMETER

The speedometer indicates the forward speed of the vehicle in miles-per-hour. The odometer registers the accumulated mileage the vehicle has been driven. Also, located in the speedometer cluster are the turn signal indicators which show direction and proper operation of the turn signals, the high beam indicator light, and the shift indicator.

### FUEL GAUGE

This gauge shows the approximate fuel level in the main tank when fuel selector switch is in the "FUEL MAIN" position, and the fuel level in the auxiliary tank when fuel selector switch is in the "FUEL AUX" position. The pointer will indicate the correct positions only when the ignition is in the "ON" position.

Since both fuel tanks are interconnected, the indicated level is designed to read the same (with the switch in either position) until approximately 60% of the total fuel capacity has been used. See "Fuel Selector Switch" later in this section.

### TEMPERATURE GAUGE

This gauge registers the temperature of the engine coolant. The center area of the water temperature gauge marks the normal operating range. However, if the needle moves beyond the center area marks into the "H" side or hot area of the gauge, stop the engine as soon as possible, and remain stopped until the cause of the overheating is determined.

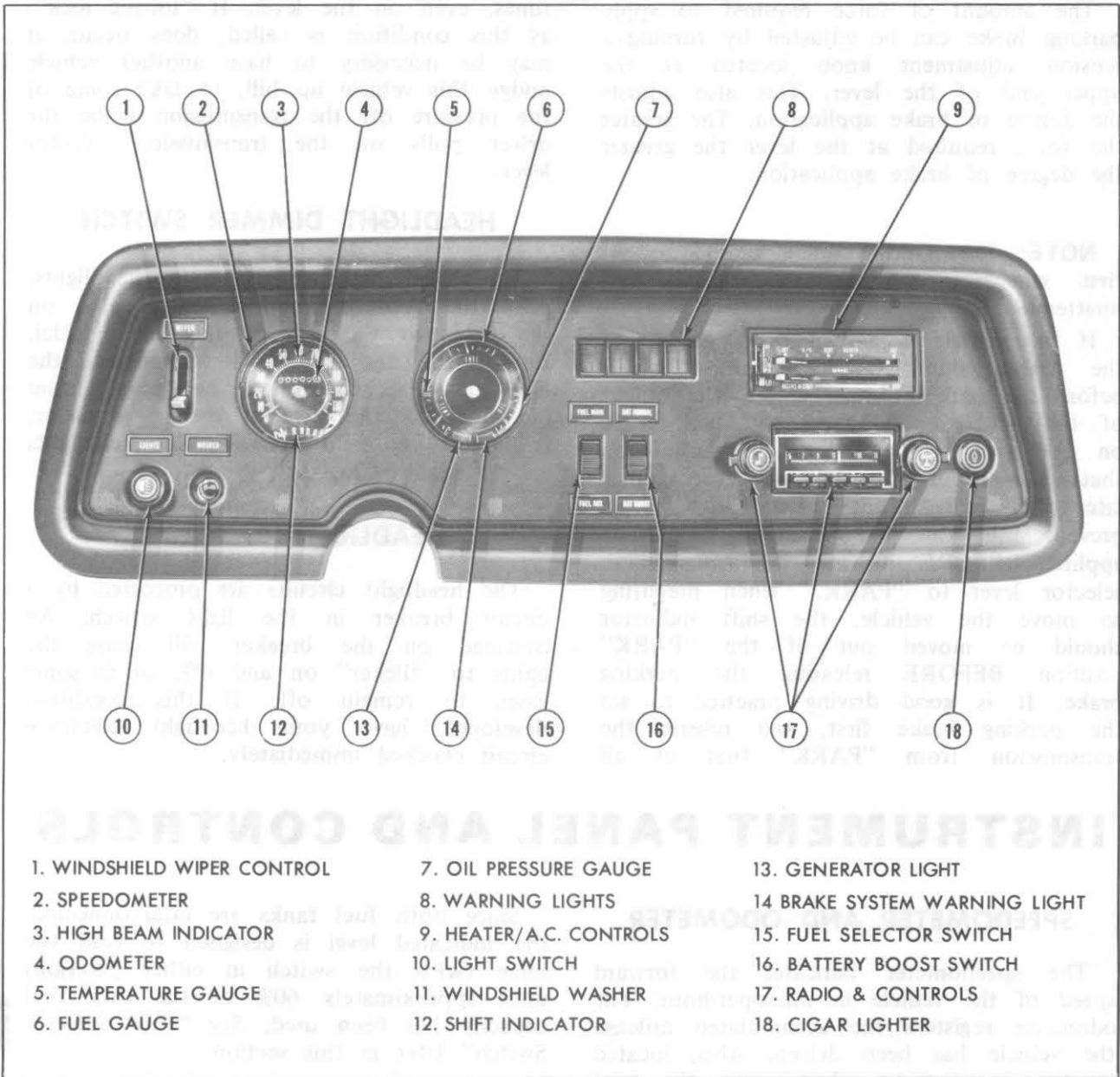

*Instrument Panel*

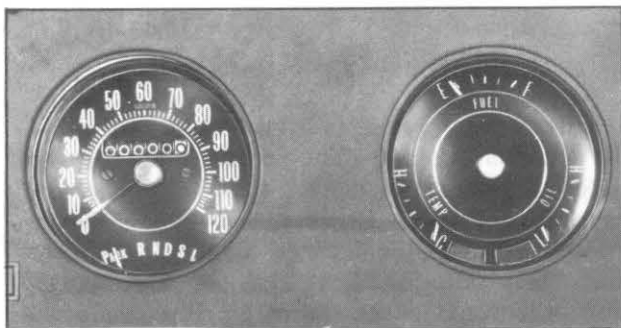

*Speedometer and Gauge Clusters*

**OIL PRESSURE GAUGE**

This gauge registers engine oil pressure. The consistency of the oil in a cool engine will cause a high reading when the engine is first started. As the engine warms, the pressure will recede to normal. With the engine warmed up to normal operating temperature, minimum pressure at idle should be slightly above the "L" graduation (8 PSI). At normal operating speeds, minimum pressure should be

between the second and middle graduations (35 PSI). Should the pressure drop below these minimums, stop the engine immediately and check the cause of the low oil pressure. This could be the result of a dangerously low oil level in the crankcase. Driving the vehicle with low oil pressure can cause extensive engine damage.

## CHARGING SYSTEM WARNING LIGHT

Located to the right of the temperature gauge is the charging system warning light. A red light "GEN" will appear with the ignition key in the "ON" position and the engine not running. This light lets you know the warning signal is operational. Should the light fail to come on, see your MotorHome dealer. When the engine is started, the warning light should go out and remain out. If the light remains on when engine is running, have your dealer locate and correct the trouble as soon as possible.

## BRAKE SYSTEM WARNING LIGHT

The service brake system is a dual system designed so that one part will provide some braking action in the event of loss of hydraulic pressure in the other part of the system. If the red warning light, located to the left of the oil pressure gauge, comes on and stays on when the ignition is on and after the brakes have been firmly applied, it may indicate that there is a malfunction in one part of the brake system.

- As a check on bulb condition the light should glow during engine starting.
- Have system repaired if light does not come on during check.
- This warning light is not a substitute for the visual check of brake fluid level required as part of normal maintenance.

### WHAT TO DO IF LIGHT COMES ON:

- The service brake system is partially inoperative.

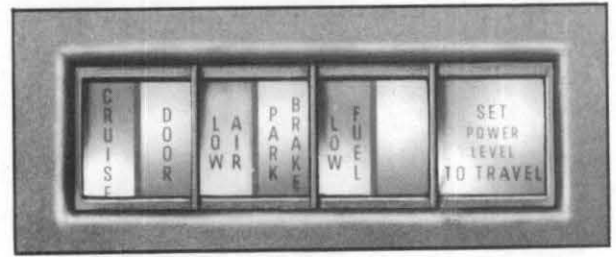

### Warning Light Cluster

1. Pull off the road and stop, carefully—remembering that:

- Stopping distances may be greater.
- Greater pedal effort may be required.
- Pedal travel may be greater.

2. Try out brake operation by starting and stopping on shoulder of road—then:

- If you judge such operation to be safe, proceed cautiously at a safe speed to nearest service outlet for repair, or
- Have vehicle towed to dealer for repair.

Continued operation of the vehicle in this condition is dangerous.

## TELL-TALE WARNING LIGHT CLUSTER

A cluster of indicator lights is located just to the left of the heater controls. These are designed to inform the driver of the status of certain systems or conditions of which he should be aware. Among these are:

- "CRUISE" (Optional Equipment)—This indicator is designed to glow GREEN whenever the Cruise Control System is engaged and working.
- "DOOR"—The door light is designed to warn the driver that the entrance door is not properly closed.
- LOW AIR—The low air light is designed to warn the driver that air pressure in the rear suspension system is abnormally low. (See "Emergency Operation," page 29, later in this section.)



*Windshield Wiper, Washer,  
and Headlight Controls*

- “PARK BRAKE”—As a reminder, the “PARK BRAKE” brake reminder light is designed to glow whenever the parking brake control is not fully released and the ignition is on.
- “LOW FUEL” (Optional Light)—The low fuel warning light in your vehicle is designed to come on when the main tank has less than five gallons of fuel left and the fuel selector switch in in the “FUEL MAIN” position. If, at any point after this, the fuel selector switch is changed to “FUEL AUX” the “LOW FUEL” warning light will then go out and come on again when the fuel

in the auxiliary tank goes below five gallons. At this point both fuel tanks of your vehicle are nearly depleted.

- “SET POWER LEVEL TO TRAVEL” (Optional Light)—This light is designed to inform the driver that the optional power level controls should be set to the “TRAVEL” position before driving the vehicle. This will allow your vehicle’s air suspension system to automatically maintain the proper suspension pressure while the vehicle is being driven. (See “Power Level System” later in this section.)

## HEADLIGHT SWITCH

The headlight switch serves four functions:

1. Pulling the switch half-way out provides parking lights, instrument panel lights, tail lights, side marker lights, and clearance and identification lights.
2. Pulling the switch all the way out provides all driving lights,—this includes headlights, plus those mentioned above.
3. To dim instrument panel lights, turn switch knob clockwise.
4. To operate the dome lights, turn switch knob fully counterclockwise.



## WINDSHIELD WIPER LEVER

The windshield wipers are variable speed, and hydraulically powered. The lever control, on the left side of the instrument panel varies the speed of the wiper blades from stop ("DOWN" position) to fast (extreme "UP" position).

## WINDSHIELD WASHERS

The windshield washers are controlled by the washer switch located under the windshield wiper lever. To operate the washers, turn the wipers to an ON position, then push down on the switch until the desired amount of washer fluid has been directed to the windshield.

- Check washer fluid level regularly—do it frequently when the weather is bad.
- Use a fluid such as GM OPTIKLEEN to prevent freezing damage, and to provide better cleaning.
- Do not use radiator antifreeze in windshield washer; it could cause paint damage.
- In cold weather, warm the windshield with defrosters before using washer—to help prevent icing that may seriously obscure vision.

## FUEL SELECTOR SWITCH

The fuel selector switch, located below the warning light cluster, has two positions—"FUEL MAIN" and "FUEL AUX." This switch allows the driver to change the fuel pick-up and fuel gauge sending unit from the main tank, as it goes empty, to the auxiliary tank which will normally contain 7 to 9 gallons of fuel. It is recommended that any time the fuel system is filled, this switch be put in the "FUEL MAIN" position and left there until auxiliary fuel is needed.

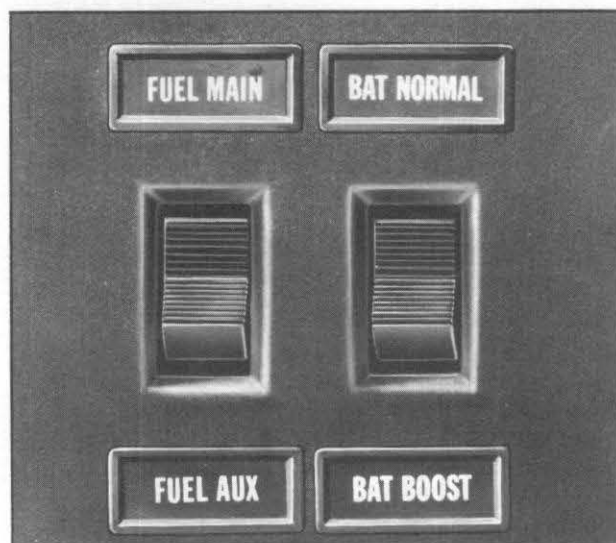

*Fuel Tank and Battery Switches*

## BATTERY BOOST SWITCH

The GMC Dual Battery System provides power from two batteries to the vehicle's 12-volt electrical system either in combination or singularly. The components used to provide charging and/or switching are conventional, except for a diode assembly with which both batteries will receive charging current whenever the vehicle is running. The diode assembly has separate outputs to the two batteries and provides isolation between the batteries and their associated circuits whenever the engine is not running.

The main battery (or automotive battery) supplies power to the chassis circuit; i.e., engine, external lights, etc. The auxiliary battery powers the vehicle's internal area; i.e., internal lights, etc.

The battery switch should be left in the "BAT NORMAL" position, except when additional power is needed for either battery circuit. If this is desired, change switch to "BAT BOOST" position. After use, it is recommended that switch be returned to the "BAT NORMAL" position.

**NOTE:** If the battery boost switch is left in the "BAT BOOST" position for extended periods this can result in both batteries being discharged.

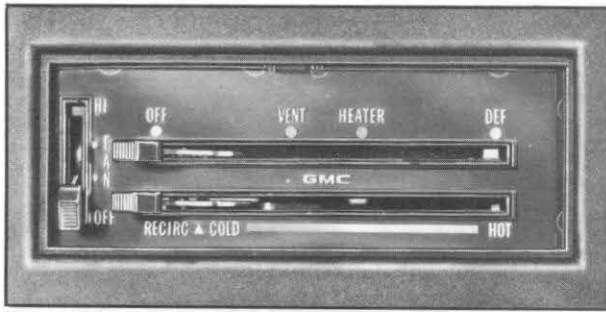

### *Automotive Heating Systems Controls*

The auxiliary battery will recharge itself while the vehicle's engine is running.

### **CIGAR-CIGARETTE LIGHTER**

Push the lighter in all the way to operate. When it is heated sufficiently to use, it is designed to "snap" back to normal position with noticeable sound. Avoid holding the lighter in by hand while it is heating.

For added safety, the cigar-cigarette lighter has a heat-sensitive terminal which is designed to melt and break the circuit if the lighter becomes overheated.

### **HEATING SYSTEM (WITHOUT AUTOMOTIVE AIR CONDITIONER)**

The heating system controls are located on the instrument panel to the right of the steering column. There are three separate controls; "FAN" lever to control speed of blower operation; "RECIRC," "COLD," "HOT" lever to control temperature of air, "OFF," "VENT," "HEATER," "DEF" lever to control direction of air flow. The "FAN" lever works vertically and the other two levers work horizontally. The three levers may be placed in any combined position to deliver the climate conditions most desirable at any given time.

● "FAN"—The fan switch has four positions; "LO" and three blower speeds ranging to "HI." Fan will operate whenever the key is in the "RUN" or

"ACCESSORY" position. In order to operate the fan in the "HI" position the engine must be running.

- "OFF," "VENT," "HEATER," "DEF"—With the lever in the "OFF" position the system is off except for the blower. With the lever in the "VENT" position 100% outside air enters the driver's compartment. The air enters through the dash mounted outlets and through the heater outlets. Temperature of incoming air may be controlled by moving the "RECIRC," "COLD," "HOT" (temperature) lever to desired position. Any one of the blower speeds may be selected.

With the lever in the "HEATER" position, air will flow through the heater floor distributor outlet (with slight flow of air to the defroster outlet). For maximum heat, move temperature lever to "HOT" position and "FAN" switch lever to "HI" position. Heating system output can be varied by moving temperature lever and "FAN" lever to different positions.

With lever in the "DEF" position, the system operates the same as in the "HEATER" position except most of the air flow will be through the defroster outlets at the windshield.

- "RECIRC," "COLD," "HOT"—This lever, used in conjunction with the system selector lever ("OFF," "VENT," "HEATER," "DEF") and the "FAN" switch lever, will control the temperature of the output air being distributed.
- Clear windshield, rear window, outside mirror, and all side windows of ice and snow before driving vehicle.
- Operate blower on "HI" for a few seconds before moving the vehicle, to clear the air intake of snow to further reduce the possibility of fogging on inside of windshield.

## AUTOMOTIVE AIR CONDITIONER

The Automotive Air Conditioning System offers year-round driving comfort. In addition to providing circulation of cool air during hot weather, the system can provide warm air in cold weather and dehumidify outside air in humid weather.

Combined air conditioning and heating system controls are located on the instrument panel in the upper right-hand corner. There are three separate controls; "FAN" lever, to control speed of blower; "OFF," "A/C," "VENT," "HEATER," "DEF" lever to control direction of air flow and which system is to be operated; "RECIRC," "COLD," "HOT" lever to control the temperature of the air. The three levers may be placed in many combined positions to deliver the climate conditions most desirable at any given

- "FAN"—The fan switch has four positions; "LO" and three blower speeds ranging to "HI." Fan will operate whenever the key is in the "RUN" or "ACCESSORY" position. In order to operate the fan in the "HI" position the engine must be running.
- "OFF," "A/C," "VENT," "HEATER," "DEF"—With the lever in the "OFF" position the system is off except for the blower. With the lever in the "A/C" position the air conditioning system is activated.

With the lever in the "VENT" position, 100% outside air enters the driver's compartment. This setting is for use during periods of less severe heat and humidity, air flow is identical to air flow in "A/C" position, however, the air conditioning compressor is not operating. Temperature of incoming air may be controlled by moving the temperature lever to the desired position. Any one of the blower speeds may be selected.

With the lever in the "HEATER" position, air will flow through the heater floor distributor outlets (with a slight flow of air to the defroster outlet). For maximum

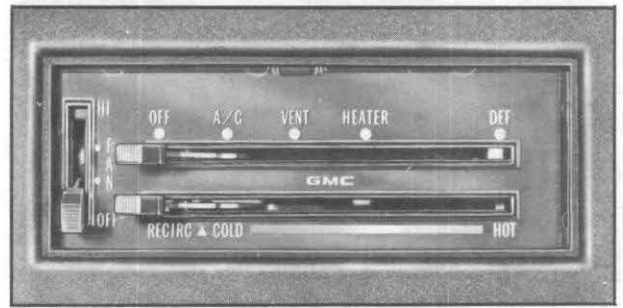

*Automotive Air Conditioner Controls*

heat, move the temperature lever to "HOT" position and "FAN" switch lever to "HI" position. Heating system output can be varied by moving temperature lever and "FAN" lever to different positions.

With the lever in "DEF" position, system operates the same as in the "HEATER" position except most of the air flow will be through the defroster outlets at the windshield.

- TYPE 1 "RECIRC," "COLD," "HOT"—This lever, used in conjunction with the system selector lever ("OFF," "A/C," "VENT," "HEATER," "DEF") and the "FAN" switch lever, will control the temperature of the output air being distributed. With the lever in the "RECIRC" position (and the upper lever in the "A/C" position) the blower automatically goes to "HI" speed providing the engine is running. This position uses 80% recirculated air. This setting will provide maximum cooling. In combination with "A/C" setting moving the temperature lever to the "COLD" position provides 100% outside air. Further movement of the temperature lever to the right (toward "HOT" position) will heat the dehumidified air to the desired temperature. The "FAN" switch can be set to meet air flow requirements.
- TYPE 2 "RECIRC," "COLD," "HOT"—The Type 2 lever differs in function, though not in appearance from the Type 1 lever. The Type 2 system is identified by additional air outlets, located below the instrument panel (as



*Location of Type 2 Air Conditioner Outlets (Typical)*

shown). With the lever in the "RECIRC" position, the additional air outlets are activated to provide maximum cooling. 100% outside air is used exclusively, regardless of lever position. The blower speed may be varied by moving the "FAN" switch position. The "COLD" and "HOT" positions allow for temperature modulation using the standard air outlets, as in the Type 1 system.

**CAUTION**

Operate in "DEF" position for 30 seconds before switching to "A/C." This will remove humid air from the system and minimize rapid fogging of the glass which can occur if humid air is blown onto a cool windshield.



*Push Button AM Radio*

- Clear windshield, rear window, outside mirrors, and all side windows of ice and snow before driving vehicle.
- Operate blower on "HI" for a few seconds before moving the vehicle, to help clear the air intake of snow to further reduce the possibility of fogging on inside of windshield.

**RADIOS AND TAPE DECK**

**PUSH BUTTON "AM" RADIO**

The "ON-OFF" switch is on the left-hand center knob with the volume control. The left-hand outside knob varies the tone response of the receiver. The right-hand center knob is used to select the station desired. The right-hand outside knob adjusts the volume of front and rear speakers.

In addition to the manual controls, this radio provides five push buttons with which to automatically select pre-set stations. To pre-set, pull the push button "out" as far as it will go, tune in the desired station manually, and then push the button "in."

Repeat this operation for each push button.

**AM-FM RADIO**

In addition to providing standard AM reception, this set permits you to receive clear static-free FM broadcasts. Move the slide bar, above the push buttons to the right or left to select AM or FM reception. All other controls remain the same as described for push button radios. FM broadcasts may be received as far as 25 miles from the sending station, depending on the power of the station and the existing terrain. In fringe areas, it may be possible to retune the radio slightly to maintain peak reception. If not, retune to a closer or stronger FM station or switch to AM operation. Push buttons may be set for both AM or FM stations as follows:

- Place slide bar in AM position.



*AM-FM Stereo Radio with Tape Deck (Tape Removed)*

- Pull push button out as far as it will go, tune in desired AM station manually and then push button in to LOCK-IN position.
- Repeat for each remaining push button.
- Place slide bar in FM position and repeat procedures outlined for AM band setting.

**IMPORTANT:** Bands should not be changed if push button is unlocked or radio may be damaged.

### ANTENNA

The radio antenna is mounted on top of the vehicle. If necessary, adjustments for maximum antenna effectiveness on AM can be made by your authorized GMC MotorHome dealer.

### STEREO RADIO

Stereo receivers permit FM stereo reception with the AM-FM radio. Radio controls are used to turn the set on and off and for station selection. For most pleasing stereo effect, the speakers are criss-crossed, with the left front and right rear speakers reproducing the left channel, and the opposite speakers reproducing the right channel. Balancing the speakers is not required as this adjustment has been made at the factory. Should it become necessary to make this adjustment, see your GMC MotorHome dealer. The indicator light will be on when the radio is tuned to an FM stereo station. Most broadcasts on such stations will be in stereo.



*AM-FM Stereo Radio with Tape Deck (Tape Installed)*

### To Tune Your Stereo Radio

- Tune radio to an FM Stereo station (one which makes the indicator light come on with a steady glow).
- Tune the lever behind the station selector knob until volume from front and rear speakers sounds equal.
- Regulate volume and tone controls as required.

### STEREO TAPE SYSTEM

The optional Stereo Tape Player provides prerecorded stereo programs for your enjoyment

To play, insert cartridge through tape door with label side up and open end in first. Tape will play through all four programs in succession, then replay in same sequence. Balancing the speakers is not required as this adjustment has been made at the factory. Should it become necessary to make this adjustment, see your GMC MotorHome dealer.

1. Rotate fader control until volume from front and rear speakers sounds equal.
2. Regulate volume and tone controls as desired.
3. To change program track, push in volume control knob and release; player will index to next track.
4. Push in the "eject" button to remove tape cartridge from player.



### *Power Level Systems Control*

#### **Cleaning and Care**

Every 100 hours of operation, or if tape slips and runs slowly, the capstan (revolving metal post), head and tape guide should be cleaned with a cotton-tipped swab moistened with alcohol (do not use carbon tetrachloride). To clean the capstan, trip the "ON-OFF" switch at the rear of the receptacle with your finger and hold the swab against the rotating capstan.

**IMPORTANT:** When tape player is not in use, remove the cartridge and store it in a cool, dry place out of direct sunlight. If the cartridge is not removed, the radio may be inoperative and possible roller damage to the tape unit could occur.

#### **MOBILE RADIO TRANSMITTERS**

Mobile radio transmitting equipment is subject to Federal Communication Commission regulations and must be installed by a qualified radio technician. The specific installation instructions for radio transmitters will vary depending upon the radio equipment used. Mobile telephone equipment installed by your local telephone company, citizens band radios and electronic garage door openers will not adversely affect vehicle operation. In the event any other type of mobile radio transmitter is to be installed, further

instructions are required so that vehicle operation will not be adversely affected. Contact GMC Truck & Coach Division, General Motors Corporation, Technical Service Department, Pontiac, Michigan 48053 (or in Canada, contact General Motors of Canada Limited, Product Service Department, Oshawa, Ontario).

#### **POWER LEVEL SYSTEM**

The optional Power Level System provides the ability to level the vehicle at campsite or parking area where the ground is not level. This system overrides the automatic leveling feature that maintains a constant ride height at the rear tandem suspension. The Power Level System can raise or lower the rear of the vehicle approximately 4 inches from normal ride height.

The Power Level Controls are located to the right of the steering wheel at the lower portion of the dash panel.

#### **NORMAL OPERATION**

The controls consist of two knobs labeled: "LEFT REAR" and "RIGHT REAR." Each knob has four positions and is used as follows:

**“RAISE”**—Knob in this position will raise rear of vehicle to any desired level, up to a maximum of 4 inches above normal ride height. When desired height is reached, turn indicator knob to **“HOLD”** position.

**“HOLD”**—When indicator line on knob is turned to this position the appropriate side of the vehicle will remain at that height. This can be done after being either in the **“RAISE”** or **“LOWER”** position. It is recommended that when vehicle is parked that the two knobs be turned to **“HOLD.”**

**“LOWER”**—With the indicator line in this position the appropriate side of the vehicle will lower a maximum of 4 inches below normal ride height. In order to maintain a desired height turn indicator on knob to **“HOLD.”**

**“TRAVEL”**—Whenever driving vehicle on highways or improved roads place indicator line in **“TRAVEL”** position. This will automatically maintain a constant ride height at the rear (approx. 8-inch ground clearance at rear). A reminder light in the dash panel is designed to light any time the engine is running and the transmission selector lever is moved to **“D”** (Drive Range).

When using Power Level the vehicle engine need not be running to operate the system, however, the ignition key must be in the **“ACCESSORY”** position.

A glass of water or a bubble type level when placed in a normally level location inside the vehicle can be used to assist in determining the desired level condition.

## OFF-ROAD OPERATION

In order to gain maximum ground clearance both control knobs should be placed in the **“RAISE”** position. It is recommended that a speed of 15 MPH should not be exceeded since the air suspension in this position has maximum pressure supplied.

## EMERGENCY OPERATION

In the event of total air loss (**“LOW AIR”** warning light illuminated) for any reason, the vehicle may be driven at a speed of 5-15 MPH (depending on road surface) with the rear of the vehicle in the fully **“DOWN”** position. Care should be exercised since ground clearance at the rear will be at a minimum. Vehicle should be taken to nearest dealer.

Depending on the type of failure, it may be possible to add air to the rear suspension air reservoir (shop air fill valve located on reservoir—see illustration) by filling reservoir at a local gas station (**DO NOT EXCEED 120 PSI**).

## MAINTENANCE

No routine maintenance is required on the Power Level System. Refer to **SERVICE AND MAINTENANCE** section later in this manual for **“Rear Suspension”** Maintenance.

## WINDOWS

The side windows in the driver's compartment are operated by squeezing the latch and sliding the window to the rear.

The optional sliding windows, if equipped with center mounted latches, are operated as follows:

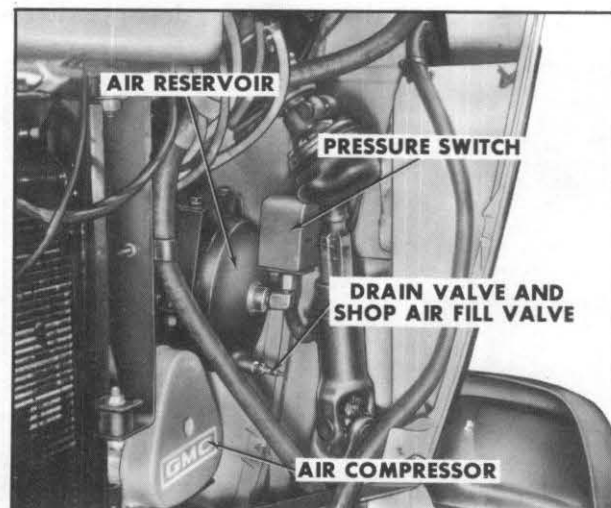

*Rear Suspension Air Components (with Vehicle Grille Removed)*

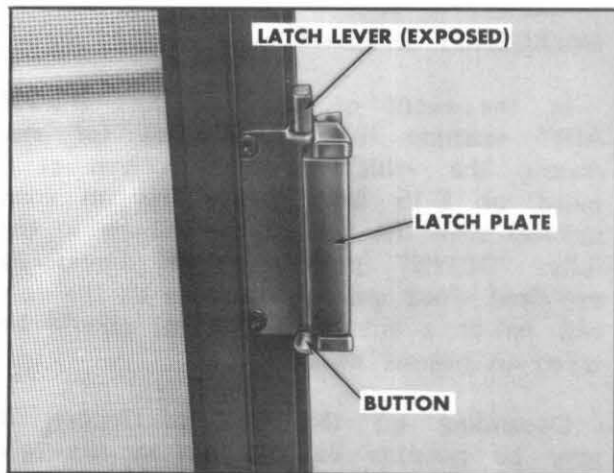

*Window Latch (Unlocked)*

## SLIDING WINDOWS

The horizontal and optional vertical sliding windows in your vehicle are equipped with a locking type latch.

### To Open Window

Unlock window latch by pushing upward on button, until latch lever is exposed (see illustration). Firmly grasp latch plate, and slide window to desired position (see illustration).

### To Close Window

Grasp latch, and slide window to the fully closed position. Push downward on

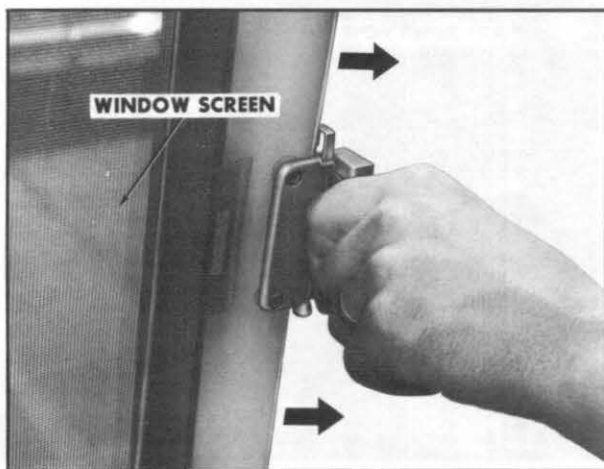

*Opening Window*

latch lever, until button is exposed (see illustration) to lock sliding window in position. To be sure window latch assembly is locked, depress latch plate and carefully attempt to open window. If window opens repeat "To Close Window" procedure. If window latch assembly still does not lock return vehicle to your dealer for service.

## ONAN MOTOR GENERATOR

**IMPORTANT:** Before operating motor generator see the carbon monoxide caution at the beginning of this section.

The motor generator is located in an exterior compartment in the left rear corner of the vehicle.

The unit is mounted on slides and can be pulled out like a drawer for ease in servicing the unit. To slide out the unit depress the buttons on the two latches. Then pull up on safety latch in upper right-hand corner and pull unit out.

## OPERATING INSTRUCTIONS

The unit can be started from a START-STOP switch that is located on the right side of the generator. Be sure the crankcase has been filled with oil to the "F" full mark on the dipstick. Check oil only when the motor generator is not operating.

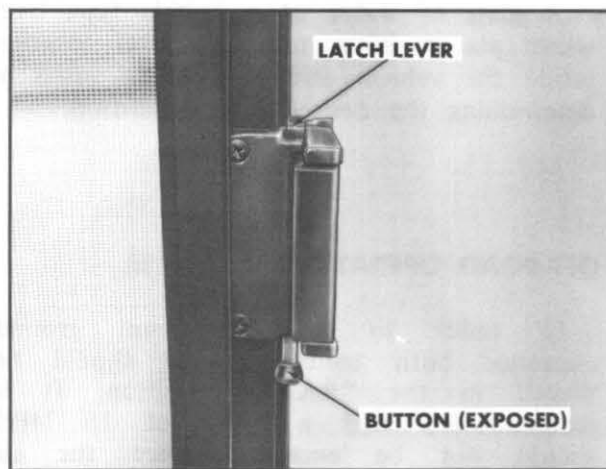

*Window Latch (Locked)*



The **START-STOP** switch is a three-position rocker switch. By pressing the top half of the switch the starter on the motor generator will be activated, hold in the switch until the unit is started. The switch should then be released. To stop the unit depress the bottom half of the switch, and hold in until the unit comes to a full stop.

**IMPORTANT:** If the motor generator has been running with a load connected, disconnect the load and allow it to run for a few minutes (with no-load connected) before pushing **STOP** button.

The circuit breaker on top of the unit will trip when the demand for electricity in amperes exceeds the motor generators capabilities. If the circuit breaker does trip, remove part of the electrical load and reset the breaker.

## HOUR METER

Located to the right of the motor generator. The **HOUR-METER** indicates total amount of hours motor generator has operated. This gauge will aid in determining when the motor generator should receive periodic inspections, maintenance and service parts replacements.

## HIGH TEMPERATURE OPERATION

Make sure that nothing obstructs air flow to and from the unit.

Keep cooling fins clean. Motor generator housing should be unaltered and undamaged.

## LOW TEMPERATURE OPERATION

1. Use correct SAE No. Oil for temperature conditions. Change oil only when engine is warm.
2. Keep fuel system clean and battery in well charged condition.

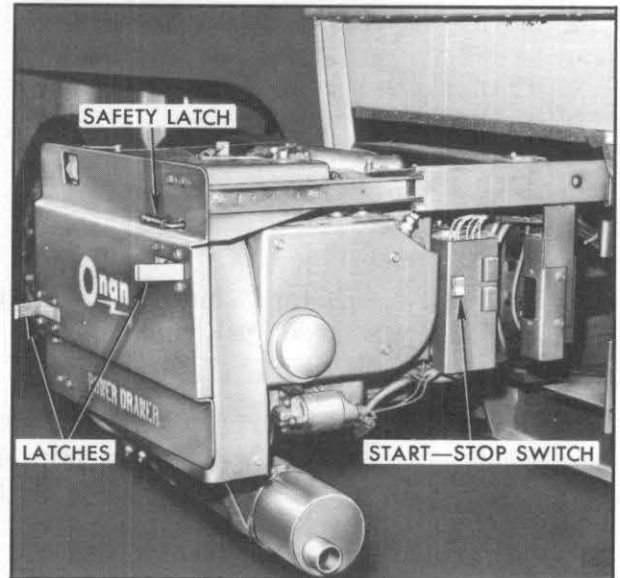

*Onan Motor Generator*

## LOW OIL LEVEL

If motor generator suddenly stops during a tight turn or sudden stop of the vehicle, the cause is most likely a low oil level. The unit is designed to shut-down when oil level is abnormally low. Before attempting to restart unit, check oil level and correct as necessary.

## DUSTY AND DIRTY OPERATION

1. Keep unit clean. Keep cooling system clean.

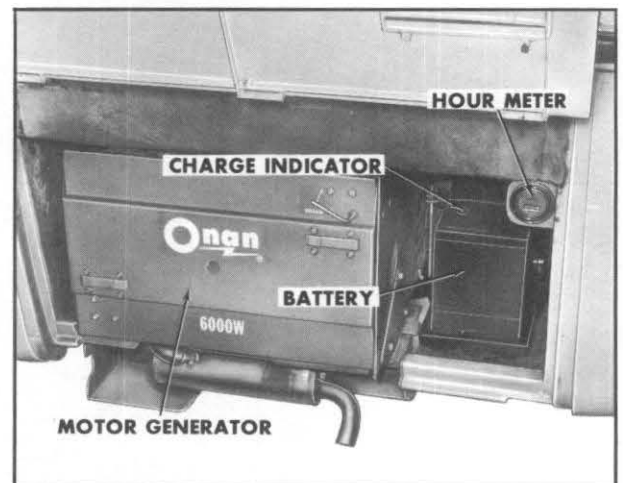

*Onan Motor Generator Compartment*

2. Service air cleaner as required.
3. Change crankcase oil and filter more often than normal.
4. Keep governor linkage clean.

**NOTE:** The motor generator may be operated while the vehicle is underway. However, the vehicle's gasoline supply will be depleted at a faster rate.

## FUEL

The motor generator's fuel is supplied from the vehicle's main fuel tank.

**For continuing satisfaction keep your vehicle all GM. General Motors Parts are identified by one of these trademarks:**



## SECTION 3

# IN CASE OF EMERGENCY

### FOUR-WAY HAZARD WARNING FLASHER

- Use the warning flasher to warn other drivers any time your vehicle becomes a traffic hazard, day or night.
  - Avoid stopping on the roadway, if possible.
  - Turn on the hazard warning flasher by pushing in on the button located on the column just below the steering wheel. Flasher can be actuated with engine ignition either off or on.
  - Turn signals do not work with hazard flashers operating.
  - If the brake pedal is depressed, the lights will not flash but remain continuously lit.
  - To cancel the flasher, pull the button out.
- The battery in the other vehicle must be 12-VOLT and NEGATIVELY GROUNDED, like the batteries in this vehicle. (Check the other vehicle's owner's manual to see if it is.)
  - The batteries in this vehicle must be equipped with FLAME ARRESTOR TYPE FILLER/VENT CAPS on ALL

### EMERGENCY STARTING

- Engine cannot be started by towing or pushing the vehicle.
- If only main (automotive) battery is discharged, set battery switch on instrument panel on "BAT BOOST," this supplies current from the auxiliary battery. Return switch to "BAT NORMAL" position if jump starting is still necessary.
- A vehicle with discharged batteries may be started by using energy from a battery in another vehicle—called "Jump Starting."

### JUMP STARTING

Jump starting may be dangerous and should be attempted ONLY if the following three conditions are met. If they are not, we strongly recommend that you leave the starting to a competent mechanic.

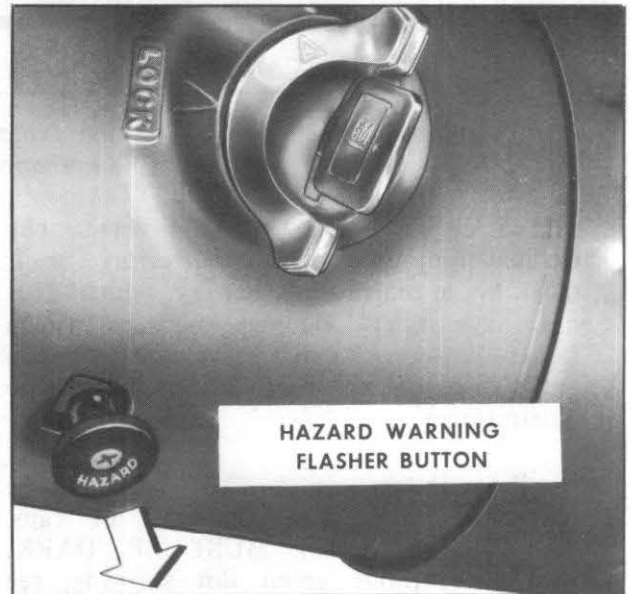

*Hazard Warning Flasher*

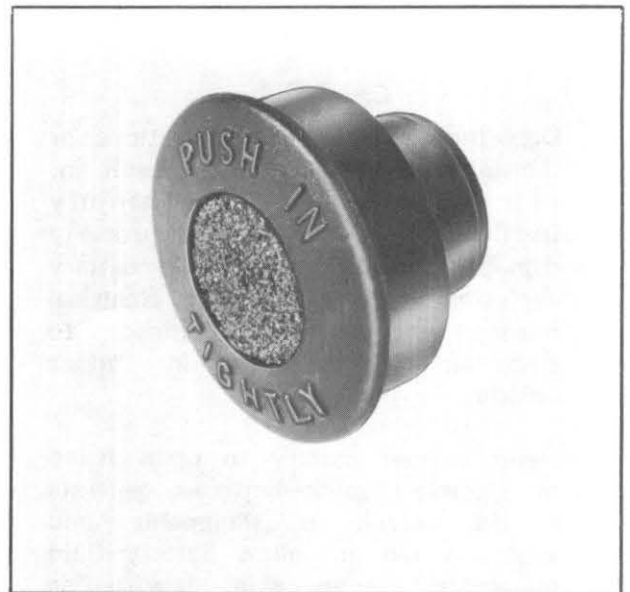

*Flame Arrestor Cap*

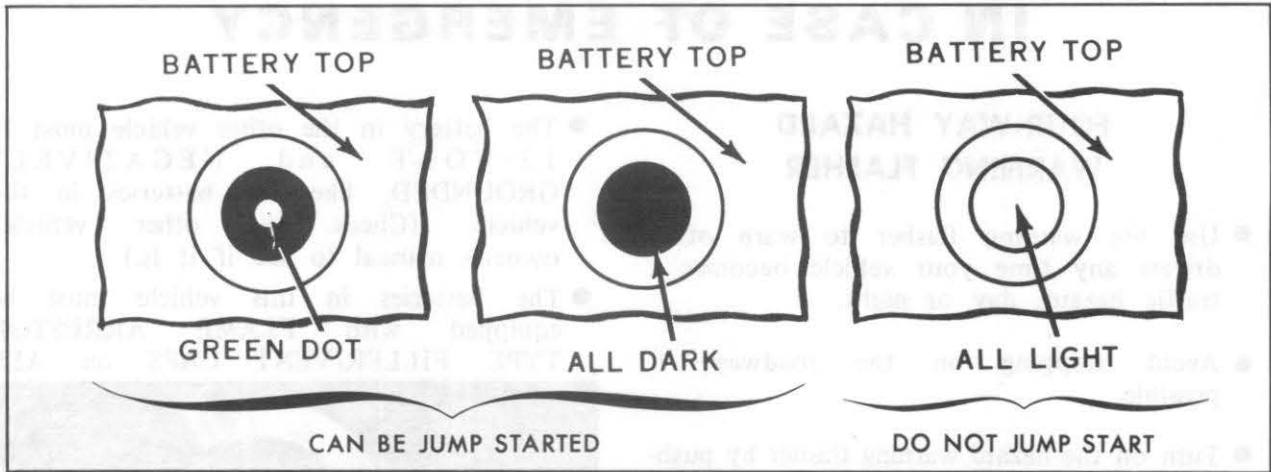

**Charge Indicator Conditions  
(Maintenance-Free Battery)**

filler openings (as was the original-equipment Delco batteries), or it must be a sealed-type battery which does not have filler openings or caps. (Each Delco battery flame arrestor cap has a grey disc rather than a small hole—see illustration.)

- If the battery is a Delco sealed-type battery without filler openings or caps, the charge indicator **MUST BE DARK**, with or without green dot showing, see illustration. Do **NOT** attempt jump starting if the charge indicator is light.

**AREA WITH WATER IMMEDIATELY AND THOROUGHLY.** Be careful that metal tools, or jumper cables do not contact the positive battery terminal (or metal in contact with it) and any other metal in the other vehicle, because short circuit could occur. Batteries and battery acid should always be kept out of the reach of children.

**CAUTION**

Departures from these conditions or the procedure below could result in: (1) serious personal injury (particularly to eyes) or property damage from such caused as battery explosion, battery acid, or electrical burns; and/or (2) damage to electronic components in either vehicle.

Never expose battery to open flame or electrical spark—batteries generate a gas which is flammable and explosive. Do not allow battery fluid to contact eyes, skin, fabrics, or painted surfaces—fluid is a corrosive acid. **FLUSH ANY CONTACTED**

**JUMP START PROCEDURE**

1. WEAR EYE PROTECTION and remove rings, metal watch bands, and other metal jewelry.
2. Set parking brake firmly, and place automatic transmission in "PARK" (neutral for manual transmission) in both vehicles; (don't let vehicles touch). Also turn off lights, heater, and all unnecessary electrical loads.
3. Attach one end of a jumper cable to the positive terminal (identified by a red color, "+", or "P" on the battery case, post, or clamp), of the battery in the other vehicle and the other end of the same cable to positive terminal junction block stud, marked "VEHICLE BATTERY POSITIVE." This is located behind the right access door above the batteries.

4. Attach one end of the remaining jumper cable **FIRST** to the negative terminal (black color, “-”, or “N”) of the **OTHER** vehicle’s battery, (regardless of which vehicle has the discharged battery—and **THEN** to the right radiator mounting bracket in **THIS** vehicle—thus taking advantage of your battery’s flame arrestor feature, should a spark occur.

5. Start the engine in the vehicle that is providing the jump start (if it was not running). Let run a few minutes, then start the engine in the vehicle that has the discharged battery.

6. Reverse the above sequence **EXACTLY** when removing the jumper cables, taking care to remove the cable from the right radiator mounting bracket in **THIS** vehicle as the **FIRST** step.

### ENGINE COOLANT CAUTION

- To avoid the danger of being burned, do not remove radiator cap while engine and radiator are still hot, because the cooling system will blow out scalding fluid and steam under pressure.
- Do not remove radiator cap to check engine coolant level; check coolant visually at the see-through coolant tank.
- Proper coolant level at normal engine operating temperature is between the “FULL” and “ADD” marks on the tank.
- Coolant should be added only to the coolant recovery tank (see **SERVICE & MAINTENANCE** section for details).

### JACK USAGE INSTRUCTIONS

#### CAUTION

1. Follow jacking instructions in order to reduce the possibility of serious personal injury.
2. The jack is designed for use only when changing wheels.
3. Never get beneath the vehicle when using jack.
4. Do not start or run engine while vehicle is on jack.

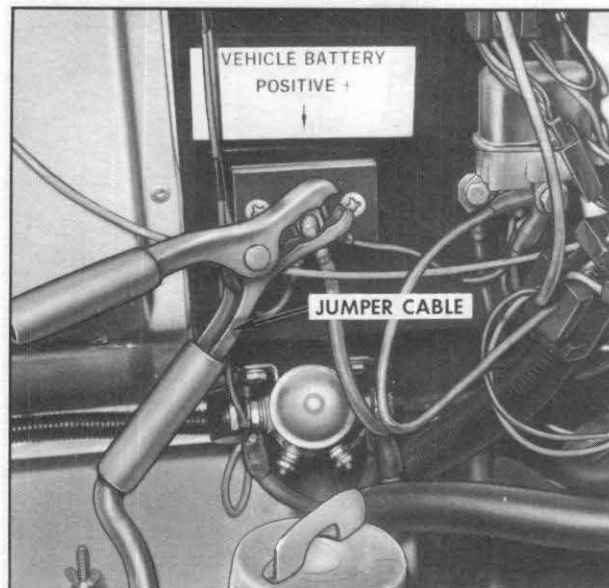

*Connecting Jumper Cable to “VEHICLE BATTERY POSITIVE” Stud*

### INSTRUCTIONS

- Park on level surface and set parking brake firmly.
- Set transmission in “PARK”.
- Activate Hazard Warning Flasher.

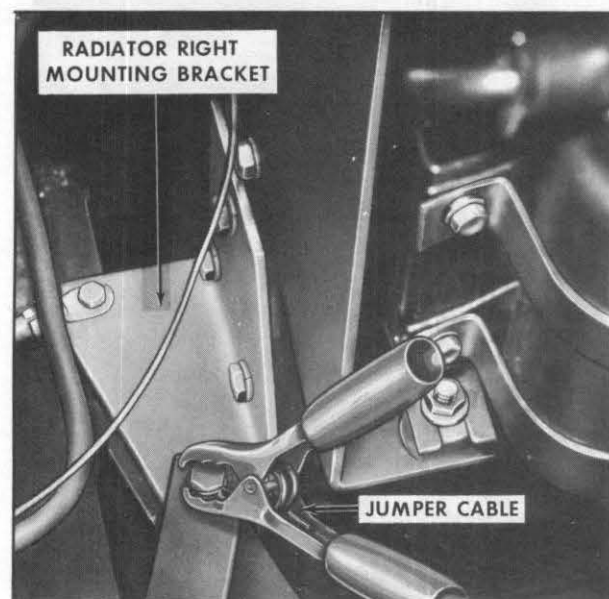

*Connecting Jumper Cable to Right Radiator Mounting Bracket*

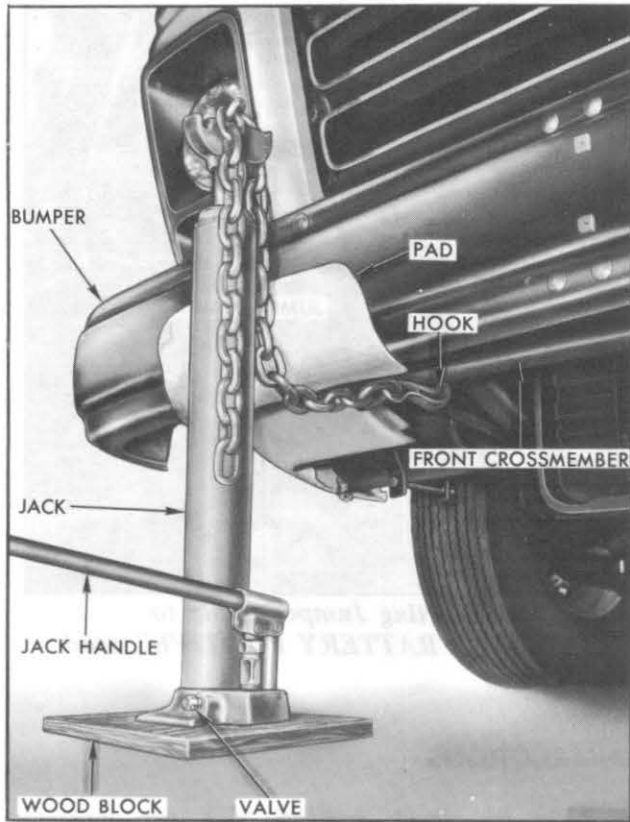

*Jacking at Front of Vehicle*

- Block both front and rear of the wheel diagonally opposite the jack position.
- Loosen but do not remove wheel nuts.
- **JACKING AT FRONT**—Place hydraulic jack on wood block near energy absorbing front bumper bracket. Place hook at flange of front cross-member. Pass chain under bumper and adjust chain length to snug fit on fork on top of jack.
- **JACKING AT REAR**—Remove fender skirt if vehicle is so equipped, using a No. 2 cross-recessed screwdriver and 9/16" wrench or socket (as shown). Place hydraulic jack on wood block close to rear suspension bracket (see illustration). The hook is placed in the drainage slot under bracket. Adjust chain length so link will fit in fork at top of jack.
- Close valve at base of jack and insert jack handle.

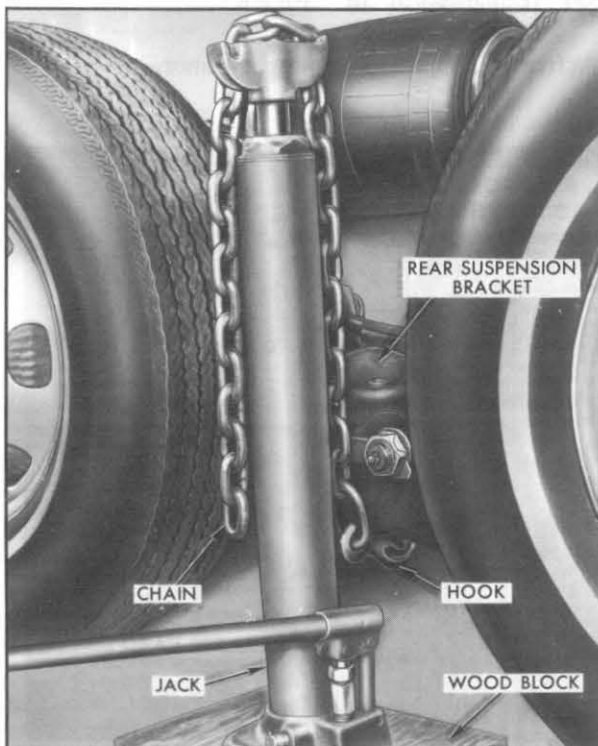

*Jacking at Rear of Vehicle*

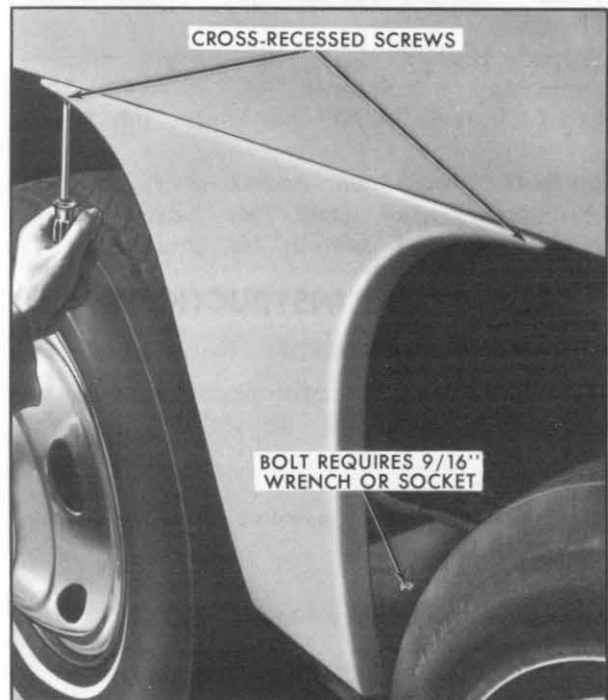

*Removing Fender Skirt*

- Raise vehicle so tire just clears surface, replace wheel and slightly tighten wheel nuts.
- Open valve at base of jack to lower, then fully tighten wheel nuts. Proper torque is 250 foot pounds.

### CAUTION

Use lug wrench provided to tighten wheel nuts securely. (Follow the nut tightening sequence shown in the SERVICE AND MAINTENANCE section). At the earliest opportunity have wheel nut torque checked. This is necessary to help prevent loosening or stripping of the wheel nuts.

Always securely restow the spare tire assembly (if so equipped) on the spare tire carrier, and return all jacking equipment to its proper stowage location. These precautions will help prevent such items from becoming dangerous projectiles in the event of an accident.

### TOWING

Proper lifting and towing equipment is necessary to prevent damage to the vehicle during any towing operation. State (Provincial in Canada) and local laws applicable to vehicles to tow must be followed. Detailed towing instructions are available at your MotorHome dealer.

Your vehicle may be towed on all six wheels, at speeds less than 35 MPH, for distances up to 50 miles, provided the final drive, axle, transmission, and steering system are otherwise normally operable. Use only towing equipment specifically designed for this purpose following the instructions of the towing equipment manufacturer. A separate safety chain system must be used. For such towing the steering must be unlocked, transmission in neutral and the parking brake released. Attachments must be to engine front crossmember. Do not attach to bumpers or associated brackets. Remember that power brakes and power steering assists will not be available when engine is inoperative.

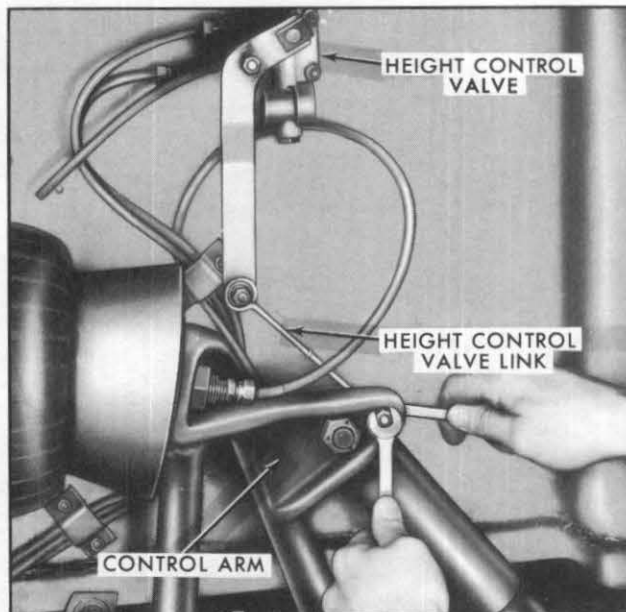

*Location for Disconnecting Height Control Valve Link*

### TOWING AT FRONT

On vehicles equipped with the Power Level System, turn the valve dials, below the instrument panel, to "HOLD" position, thereby making the automatic height valves inoperative on the rear suspension. On vehicles not equipped with the optional Power Level System it will be necessary to disconnect the height control valve link at the rear suspension control arm (adjacent to the shock absorber stud) on each side of the vehicle. Raising front of vehicle so front wheels are four inches off the ground will provide about five-inch ground clearance at the rear when towing.

### TOWING AT REAR

It is not recommended that vehicle be towed with the rear raised as this could result in suspension or crossmember damage.

### FREING VEHICLE FROM SAND, ETC.

If it becomes necessary to rock the MotorHome to free it from sand, mud, or snow, move the transmission selector lever from "D" to "R" in a repeat pattern

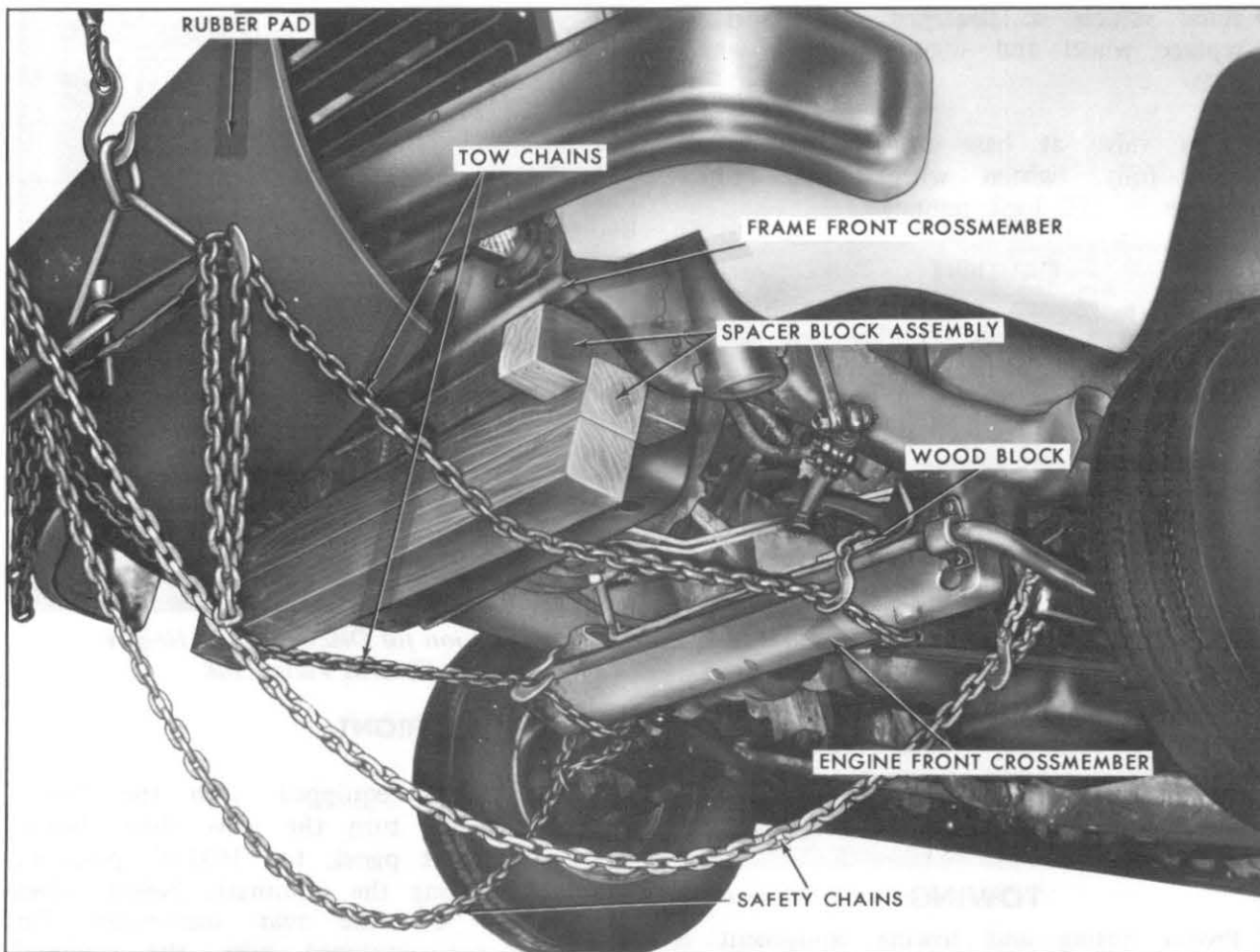

*Towing Vehicle*

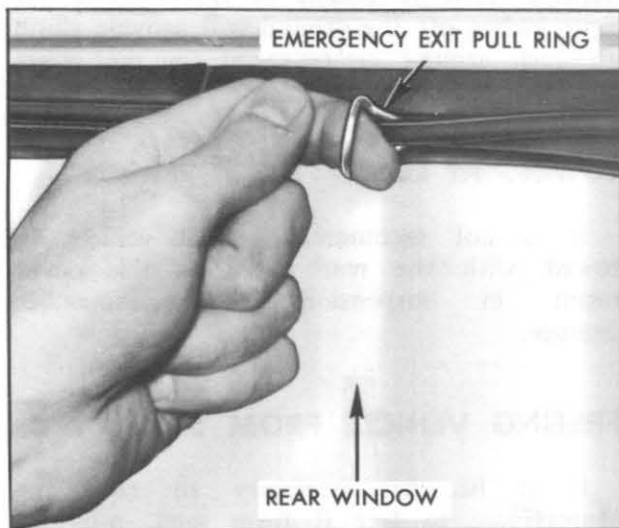

*Emergency Exit Pull Ring*

while simultaneously applying moderate pressure to the accelerator. Do not race engine. For best possible traction, avoid spinning wheels when trying to free the vehicle. The use of GM Liquid Tire Chain is recommended for temporary assistance when traction is lost on ice or snow.

**CAUTION**

Do not spin wheels in excess of 35 MPH as indicated on the speedometer. Personal injury and severe damage may result from excessive wheel spinning including tire disintegration or differential failure.



## EMERGENCY EXIT

The rear window of the vehicle in an emergency can be used as an exit. To use the emergency exit, pull the ring located at the top center of the rear window until window seal is removed, and then push the

glass out of the frame. Do not pull ring except in case of emergency. The window is not hinged, and it is designed to be pushed out. Take care that window will not fall on anyone outside the vehicle. Be careful of possible broken glass on ground when exiting from the vehicle.

For continuing satisfaction keep your vehicle all GM. General Motors Parts are identified by one of these trademarks:



## SECTION 4

# APPEARANCE CARE

## CARE AND CLEANING OF INTERIOR (DRIVER'S COMPARTMENT)

### GENERAL INFORMATION

Dust and loose dirt that accumulates on interior fabric trim should be removed frequently with a vacuum cleaner, whisk broom or soft brush. Vinyl or leather trim should be wiped regularly with a clean damp cloth. Normal trim soilage, spots or stains can be cleaned with GM cleaners or equivalent.

Before attempting to remove spots or stains from upholstery, determine as accurately as possible the nature and age of the spot or stain. Some spots or stains can be removed satisfactorily with water or mild soap solution (refer to "Removal of Specific Stains" later in this section). For best results, spots or stains should be removed as soon as possible.

Some types of stains or soilage such as lipsticks, some inks, certain types of grease, mustard, etc., are extremely difficult and,

in some cases, impossible to completely remove. When cleaning this type of stain or soilage, care must be taken not to enlarge the soiled area. It is sometimes more desirable to have a small stain than an enlarged stain as a result of attempted cleaning.

The listed cleaners are EXCELLENT CLEANERS when used properly according to directions on containers and are available through most G.M. Dealerships.

### LAP BELT CARE

- Clean only with mild soap solution and lukewarm water.
- Do not bleach or dye belts since this may severely weaken belts.

## G.M. CLEANERS

PART NO.	QUANTITY	DESCRIPTION
1050244	16 oz. can	G.M. Fabric Cleaner (Solvent Type)
1050417	Gallon can	G.M. Fabric Cleaner (Solvent Type)
1050803	16 oz. Container	G.M. Multi-Purpose Powdered Cleaner (Foam Type)
1050429	6 lb. can	G.M. Multi-Purpose Powdered Cleaner (Foam Type)

### INTERIOR GLASS

The interior glass surface should be cleaned on a periodic basis for continued good visibility. A commercial household glass cleaning agent containing ammonia will remove normal tobacco smoke and dust films sometimes caused by ingredients used in vinyls, plastics, or other interior trim materials.

#### HEHR WINDOWS

If your vehicle is equipped with Hehr windows, identified by center mounted latches, removal and installation of screens to aid in cleaning interior glass may be accomplished in the following manner:

#### WINDOW SCREEN REMOVAL

**IMPORTANT:** To help avoid damaging screen track, DO NOT remove screen before removing screen track.

1. Remove upper screen track using a reasonably stiff wire shaped to form the screen track removal tool (as shown). Insert tool at outer end of screen track and separate track from window frame assembly. Grasp track and pull completely free of window assembly.

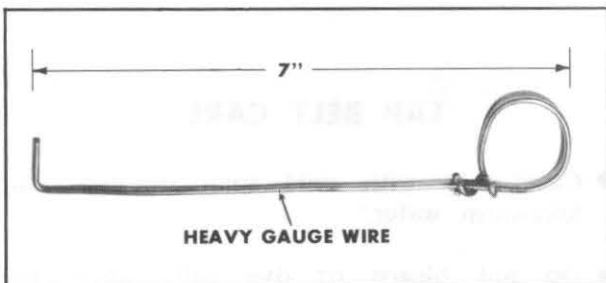

*Screen Track Removal Tool*

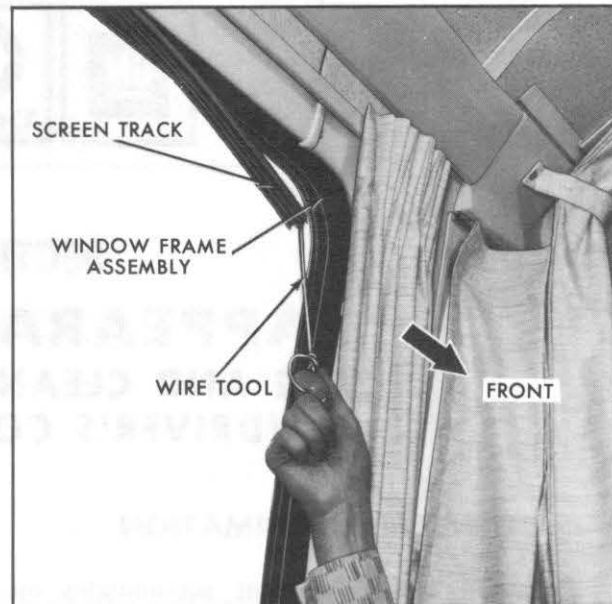

*Separating Track From Window Frame Assembly (Typical)*

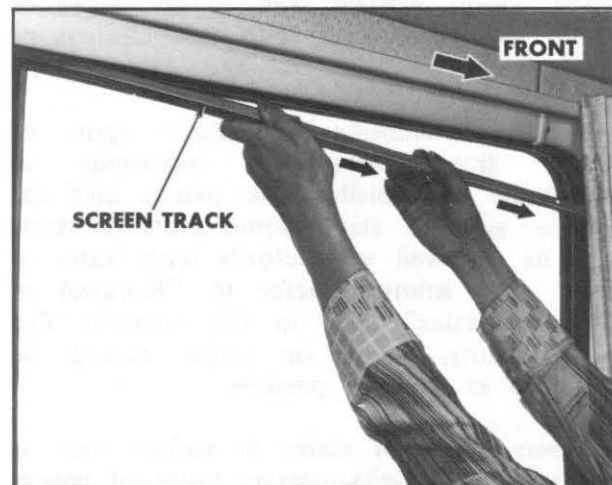

*Removing Screen Track (Typical)*

2. Unlock window, slide glass and screen forward almost to moulding retainers.

3. Lift screen up into window frame assembly. Pull bottom of screen away from window and remove screen.

### WINDOW SCREEN INSTALLATION

1. To install screen, lift screen up into window frame assembly. Slide screen fully rearward.

2. Note that screen track when installed contacts the inner edge of sliding window track. The screen track has three grooves, and the widest groove should face the outside of the vehicle. Position screen track in window frame assembly and slide it rearward until contact is made with adjacent upper screen track. Seat track into position by pressing track firmly up into window frame assembly.

3. Slide screen back and forth several times to assure proper seating of track. If screen will not slide, track is binding. Using a small wood block and mallet, carefully tap the track firmly into position.

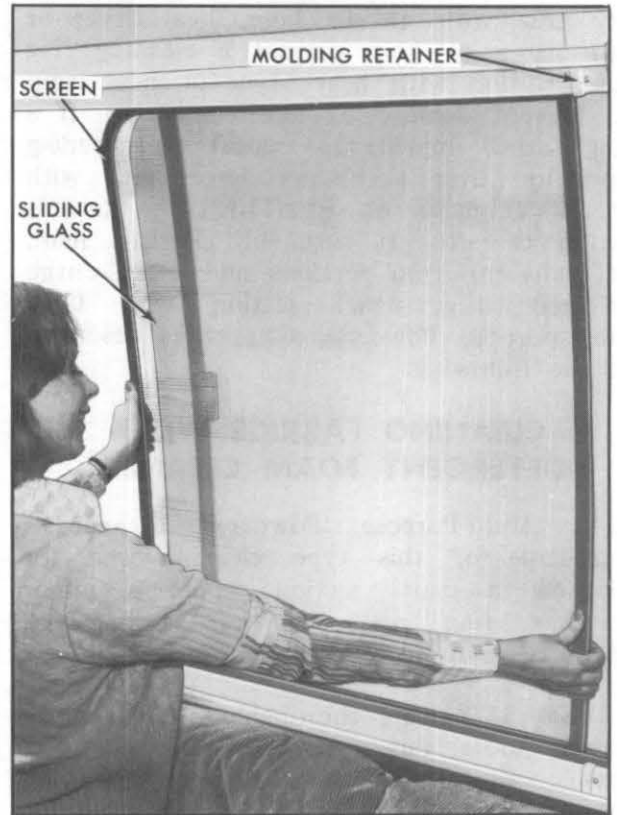

*Removing Window Screen (Typical)*

#### CAUTION

DO NOT use a screwdriver to install screen track. The screwdriver may fracture the window glass.

removers; or such cleaning materials as laundry soaps, bleaches or reducing agents (except as noted in the adjacent fabric cleaning instructions on stain removal). Never use carbon tetrachloride, gasoline or naphtha for any cleaning purpose.

### CLEANING FABRICS

**IMPORTANT:** Be sure vehicle is well ventilated while using any cleaning agents. Follow manufacturer's recommendations in using such products.

### CLEANING FABRICS WITH CLEANING FLUIDS

#### CAUTION

Many cleaners may be toxic or flammable, and their improper use may cause personal injury or may cause damage to the interior. Therefore, when cleaning the interior, do not use volatile cleaning solvents such as: acetone, lacquer thinners, enamel reducers, nail polish

G.M. Fabric Cleaner (Solvent Type) is excellent for spot cleaning stains containing grease, oil or fats from fabric type trim. Excess stain should be gently scraped off trim material with a clean DULL knife or scraper. USE VERY LITTLE CLEANER, light pressure, and clean cloths (preferably cheese cloth). Cleaning action should be from outside of stain FEATHERING towards center of stain and constantly changing to a clean section of cloth. When stain is cleaned from fabric, immediately

dry area with an air hose, heat dryer or heat lamp to help prevent a cleaning ring (use caution with heat dryer or heat lamp to prevent damage to fabric material). If a ring forms, immediately repeat the cleaning operation over a slightly larger area with special emphasis on FEATHERING towards center of area. If ring still persists, mark off adjacent trim sections and clean entire affected trim panel section with G.M. Multi-purpose Powdered Cleaner as described in the following:

### **CLEANING FABRICS WITH DETERGENT FOAM CLEANER**

G.M. Multi-Purpose Powdered Cleaner is excellent for this type cleaning and for cleaning a panel section where a minor cleaning ring may be left from spot cleaning.

Vacuum area thoroughly to remove excess loose dirt. ALWAYS clean a full trim assembly or complete trim section—mask adjacent trim along stitch or welt lines. Mix Multi-Purpose Powdered Cleaner in strict accordance with directions on label of container—mix proportionally for smaller quantities. USE SUDS ONLY ON A CLEAN SPONGE or SOFT BRISTLE BRUSH—DO NOT WET FABRIC EXCESSIVELY OR RUB HARSHLY WITH BRUSH. IMMEDIATELY AFTER CLEANING WIPE OFF ANY CLEANER RESIDUE WITH SLIGHTLY DAMP ABSORBENT TOWEL OR CLOTH.

**IMPORTANT—IMMEDIATELY AFTER WIPING, FORCE-DRY FABRIC WITH AIR HOSE, HEAT DRYER OR HEAT LAMP. (Use caution with heat dryer or heat lamp to prevent damage to fabric.)**

When trim materials with a sheen or luster finish are dry, wipe fabric lightly with a soft, dry clean cloth to restore sheen or luster.

### **REMOVAL OF SPECIFIC STAINS**

**CANDY**—Chocolate, use cloth soaked in lukewarm water; other than chocolate, use

very hot water. Dry if necessary, clean lightly with fabric cleaning fluid.

**CHEWING GUM**—Harden gum with ice cube and scrape off with dull knife. Moisten with fabric cleaning fluid and scrape again.

**FRUIT STAINS, COFFEE, LIQUOR, WINE, SOFT DRINKS, ICE CREAM AND MILK**—Wipe with cloth soaked in cold water. If necessary, clean lightly with fabric cleaning fluid. Soap and water is not recommended as it might set the stain.

**CATSUP**—Wipe with cloth soaked in cool water. If further cleaning is necessary, use a detergent foam cleaner.

**GREASE, OIL, BUTTER, MARGARINE AND CRAYON**—Scrape off excess with dull knife. Use fabric cleaning fluid.

**PASTE OR WAX TYPE SHOE POLISH**—Light application of fabric cleaning fluid.

**TAR**—Remove excess with dull knife, moisten with fabric cleaning fluid, scrape again, rub lightly with additional cleaner.

**BALL POINT INK**—Try rubbing alcohol. If stain remains after repeated operations, no other measure should be tried.

**LIPSTICK**—Difficult to remove. Cleaning fluid works on some brands. If stain remains after repeated applications, do not try other measures.

**MUSTARD**—Damp sponge with warm water, then rub detergent on dampened stain and work into fabric. Rinse with clean damp cloth. Repeat several times. Some discoloration may remain.

**BLOOD**—Wipe with clean cloth moistened with cold water. Use no soap.

**URINE**—Sponge stain with lukewarm soap suds from mild neutral soap on clean cloth, rinse with cloth soaked in cold water; saturate cloth with one part household ammonia and five parts water, apply for one minute, rinse with clean, wet cloth.

**VOMITUS**—Sponge with clean cloth dipped in clean, cold water. Wash lightly with lukewarm water and mild neutral soap. If odor persists, treat area with a water-baking soda solution (one teaspoon baking soda to one cup of warm water). Rub again with cloth and cold water. Finally, if necessary, clean lightly with fabric cleaning fluid.

## **EXTERIOR APPEARANCE CARE**

The best way to preserve the finish is to keep it clean. Normally only frequent washings are required to maintain its original beauty. Wash the vehicle with either cold or warm (never hot) water, not in the direct rays of the sun and not while the sheet metal surfaces are hot. Never wipe dirt from dry painted surfaces because this may scratch the finish. The use of strong soaps and chemical detergents should be avoided. Cleaning agents should be promptly flushed from the surface and not allowed to dry or they may streak the finish.

### **BRIGHT METAL PARTS**

Wash all bright metal parts frequently to alleviate the destructive forces of salt, calcium chloride, salt air, exhaust gases, and industrial fallout (which may be corrosive).

Use lukewarm water and mild soap, not with a strong alkali solution, rinse thoroughly. Avoid use of bright metal polishes containing harmful abrasives.

**NOTE:** In severe cases, road oil and tar may be removed from bright metal parts by a chemical cleaner which is specified safe to use on all acrylic finishes.

A protective coating such as GM Chrome Gard may be applied on clean chrome surfaces which are stain and rust free. If necessary, GM Chrome Cleaner and Polish may be used to remove rust from chrome plated parts before applying a protective coating.

### **EXTERIOR GLASS**

Never wipe glass with dry paper or cloth. Do not operate wipers when glass is dry. Dirt and insects can be removed with clear water or with a mild liquid household cleaner. The use of harsh abrasives should be avoided. Periodic inspection and replacement of wiper blades will reduce the possibility of the windshield becoming scratched and will assure clear vision under adverse driving conditions.

### **POLISHING AND WAXING**

Even though the acrylic enamel on your vehicle is durable, under certain conditions it may be advisable to wax or polish your vehicle to provide added protection. Calcium chloride and other salts, road oil and tar, tree sap, chemicals from factory chimneys and other foreign matter may damage any known vehicle finish if allowed to remain in contact with the paint film.

Prompt washing may not remove thoroughly these deposits and, particularly in geographical areas where exposure conditions are severe. Properly applied polished and waxes of known quality will provide the best protection. Most GMC MotorHome dealers offer polishes or waxes which can be of real value in maintaining a good paint finish.

**NOTE:** Some chemical cleaners, used for removing road oil and tars from painted surfaces, are detrimental to acrylic enamel finishes. When purchasing a cleaner, make sure the instructions on the container specifically state that the contents can be used on any acrylic enamel finish.

## TOUCH-UP PAINT

Nicks and chips in paint surfaces should be touched up before weathering action begins. The best time to detect them is right after the vehicle has been washed. Touch-Up Paint to match your vehicle's color is available at your GMC MotorHome dealer.

## UNDERCOATING

Due to the fiberglass and aluminum body construction of the vehicle added protection by additional undercoating is not necessary. However, if you do wish to apply undercoating material, it should be kept off of all moving or rotating parts. It should also be kept off air conditioner fittings, body drain holes, exhaust systems, and plumbing.

**For continuing satisfaction keep your vehicle all GM. General Motors Parts are identified by one of these trademarks:**



## SECTION 5

# SERVICE AND MAINTENANCE

### CAUTION

As with any machinery, extreme care should be taken when performing any inspection, maintenance or repairs so as to prevent accidental injury. Improper or incomplete servicing could result in vehicle operational problems which may lead to personal injury, or damage to the vehicle or its equipment. Should you have any question about performing any service, have the service performed by a competent serviceman.

### MAINTENANCE SCHEDULE

For owner convenience, a separate maintenance folder has been provided with your vehicle which contains a complete schedule and brief explanation of the safety, emission control, lubrication and general maintenance it requires. The maintenance folder information is

supplemented by this section of the Operating Manual, as well as a Warranty Information folder also furnished with your vehicle. Read all three publications for a full understanding of vehicle maintenance requirements.

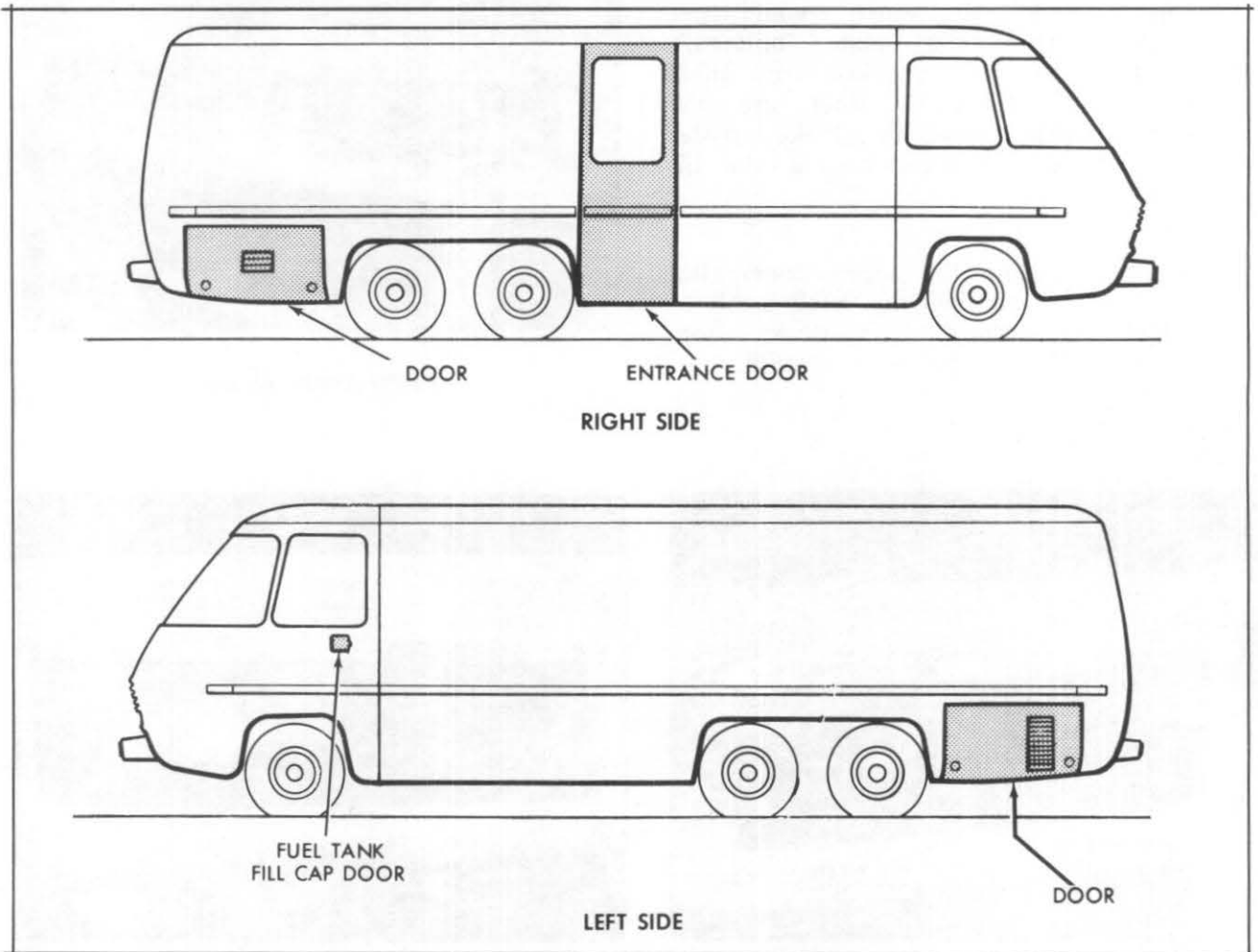

*Exterior Compartment Location (Typical)*

# ACCESSIBILITY

## EXTERIOR COMPARTMENTS

Your vehicle has an entrance door on the right side and six compartment doors. Their locations are shown on the following illustrations.

Be sure the doors are secured tightly to prevent their opening after vehicle is in motion.

There are two front access doors on your vehicle. Turn the latch knob to the left to release each door. Items that can be checked or filled through the right access door are the batteries, engine oil fill, radiator, radiator cap, engine coolant reservoir and the air conditioner receiver-dehydrator sight glass (optional). Items that can be checked or filled through the left access door are the windshield washer reservoir, brake master cylinder and the engine oil dipstick.

Be sure to secure the access doors after closing them by turning the latch knob to the right to prevent the doors from opening after the vehicle is in motion.

## CAUTION

Before pouring fluid into any opening anywhere on the vehicle, or allowing anyone else to do so, make certain that the correct filler opening, and type of fluid has been selected. A wrong choice could result in serious personal injury or property damage.



*Front Access Doors*

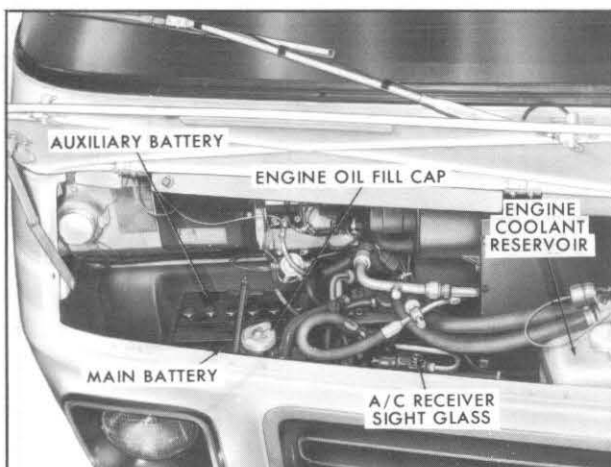

*Right Front Access Compartment*

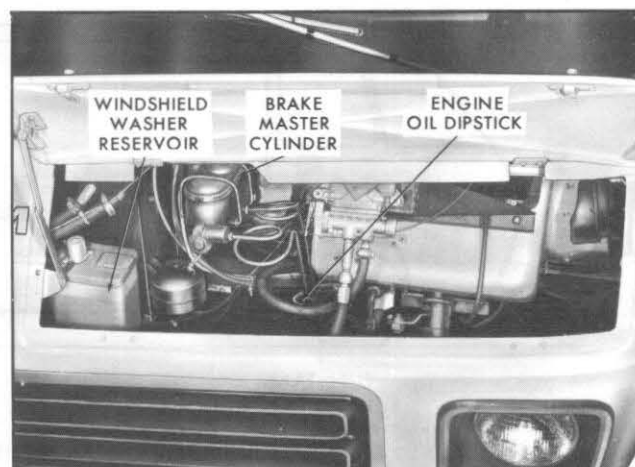

*Left Front Access Compartment*



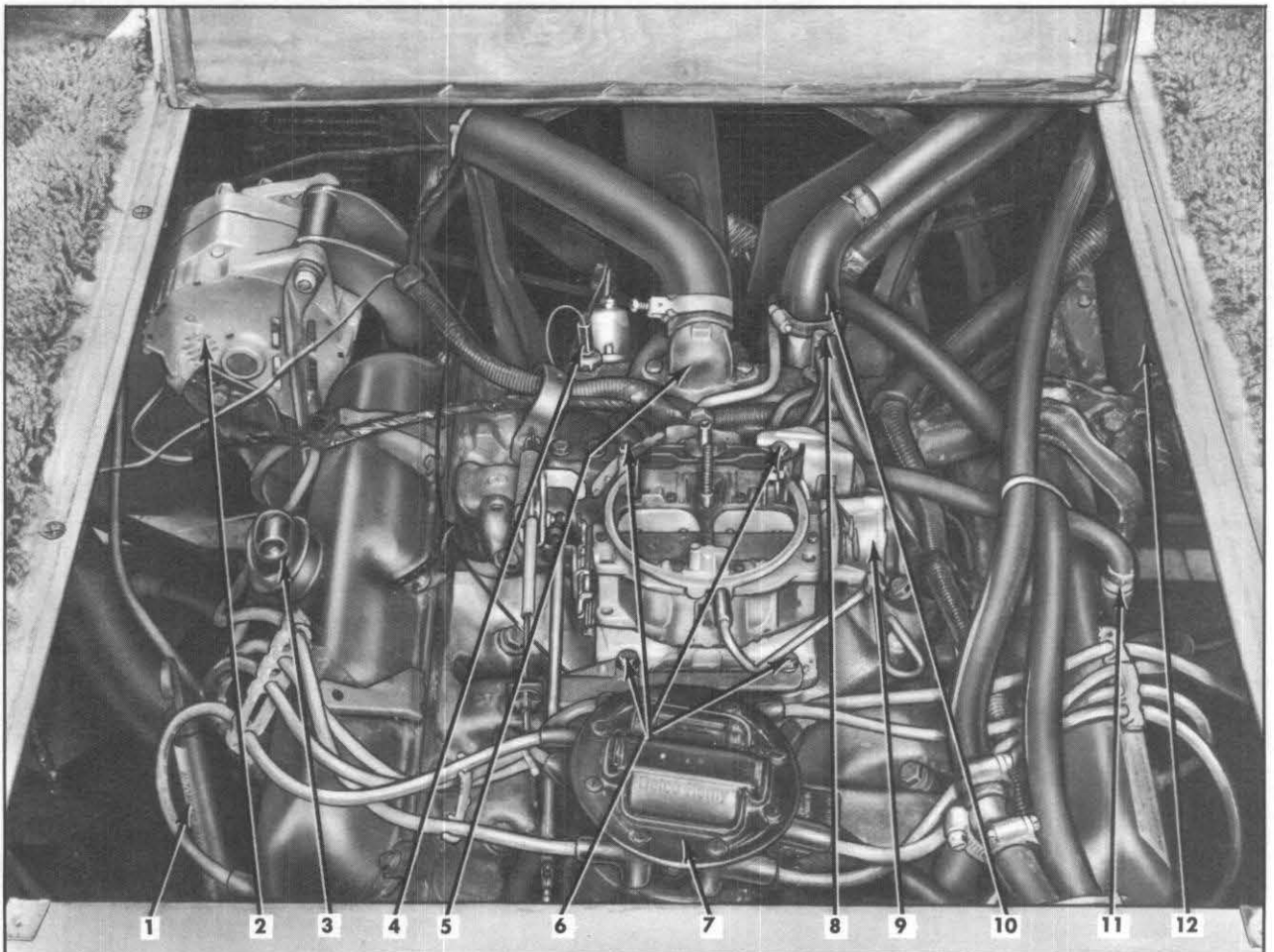

- |  |  |
|--|--|
| 1. Automatic Transmission Fluid Dipstick and Fill Tube | 7. Distributor                             |
| 2. Generator   | 8. Thermal Vacuum Switch                   |
| 3. PCV Filter  | 9. Carburetor Choke Coil Cover             |
| 4. Engine Temperature Sending Unit                     | 10. Engine Oil Fill Hose and Tube Assembly |
| 5. Thermostat Housing                                  | 11. PCV Valve                              |
| 6. Carburetor Attaching Bolts (4)                      | 12. Air Conditioning Compressor (Optional) |

### *Engine Compartment*

#### **ENGINE ACCESSIBILITY**

Access to the engine is provided by an engine cover located between the driver and passenger seats. The cover is designed to be secured at the two rear corners by securing bolts. The securing bolts have rings

and may be loosened or tightened by hand or screwdriver. The cover is designed to be secured at the front by a retaining lip.

To remove the engine cover loosen the securing bolts and lift up using the wire loops. To install the engine cover place the cover in its frame and slide forward as far as possible. Tighten the securing bolts.

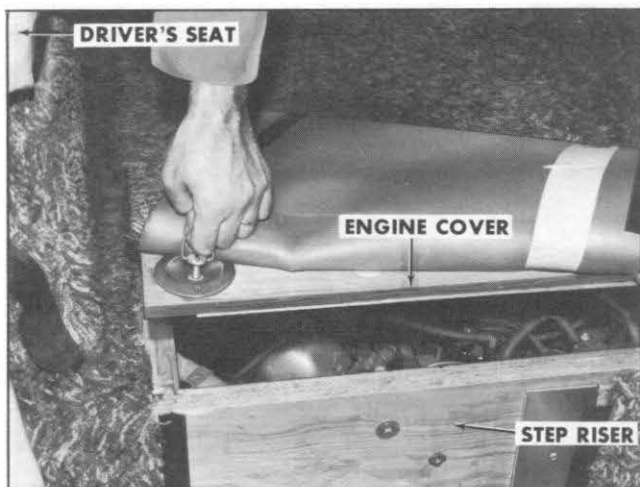

*Removing Engine Access Cover*

## ENGINE COMPARTMENT LIGHT

The optional engine compartment light (located behind right front access door) is turned ON when access door is opened. The light, attached to a 25-foot cord, may be removed from engine compartment for use as necessary.

## CAUTION

It is essential that when installing the engine cover it be fully seated to its seal and secured by the lip at its forward edge and the securing bolts at its rearward edge. Do NOT allow cables, carpeting, floor mats or any other material to interrupt the seat between the cover and the engine compartment. If the engine cover is not correctly installed and seated, engine exhaust could leak into the passenger compartment creating a safety hazard (see the carbon monoxide caution at the beginning of the section on STARTING AND OPERATING VEHICLE). If the engine must run with the cover off for maintenance purposes, care should be taken to assure that the vehicle's interior is well ventilated.

# HOISTING INSTRUCTIONS

A twin post hoist of sufficient capacity and with proper adapters and/or fittings must be used.

Front hoisting position is the front engine crossmember.

Rear hoisting must be done at the rear suspension brackets. If an "I" beam type adapter is used it should be approximately 82 inches in length to gain adequate support at suspension brackets.

If the vehicle is to be placed on safety stands for maintenance or repairs, the hoisting points should be used.

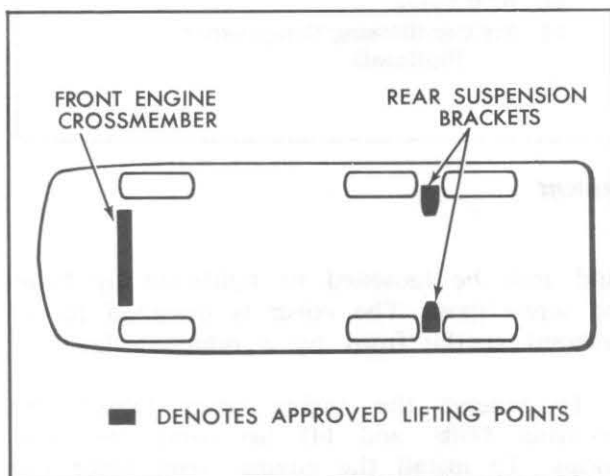

*Vehicle Hoisting Points*

## CAUTION

To help avoid serious damage to your vehicle, the vehicle should be raised only on twin post hoists of 15,000 pounds or more total rated capacity, at the suspension points noted (see diagram). Before raising, check overhead clearance to see that it is sufficient for the vehicle. DO NOT use the vehicle jack for hoisting or maintenance. It is designed for use only when changing tires.

# LUBRICATION DETAILS

## ENGINE

### ENGINES OIL AND FILTER RECOMMENDATIONS

- Use only SE engine oil.
- Refer to Maintenance Schedule folder for oil change and filter replacement intervals.
- See your GMC MotorHome dealer for advice on the frequency of oil and filter changes under unusual driving conditions.

The recommendations in the Maintenance Schedule folder apply to the first change as well as subsequent oil changes. The oil change interval for your vehicle's engine is based on the use of SE oils and quality oil filters. Oil change intervals longer than those listed will seriously reduce engine life and may effect GMC Truck & Coach's obligation under the provisions of the New Vehicle Warranty.

A high quality SE oil was installed in your engine at the factory. It is not necessary to change this factory-installed oil prior to the recommended normal change period. However, check the oil level more frequently during the break-in period since higher oil consumption is normal until the piston rings become seated.

NOTE: Non-detergent and other low quality oils are specifically not recommended. Only the use of SE engine oils and proper oil and filter change intervals assure you of continued proper lubrication of your vehicle's engine.

### RECOMMENDED SAE VISCOSITY

- Single grade oils are preferred, however, multigraded such as SAE 10W-30 or 10W-40 are also acceptable.
- SAE 5W-20 oils\* are not recommend for sustained high speed driving.
- SAE 5W-30 oils (if available) may be used if extreme low temperatures are anticipated.

## SUPPLEMENTAL ENGINE OIL ADDITIVES

The regular use of supplemental additives is specifically not recommended and will increase operating costs. However, supplemental additives are available that can effectively and economically solve certain specific problems without causing other difficulties. For example, if higher detergency is required to reduce varnish and sludge deposits resulting from some unusual operational difficulty, a thoroughly tested and approved additive—"Super Engine Oil Supplement"—is available at your GMC MotorHome dealer. In the event of an operational problem, consult your dealer for advice before using supplemental additives.

## CHECKING OIL LEVEL

The engine oil should be maintained at the proper level. The best time to check it is before operating the engine or as the

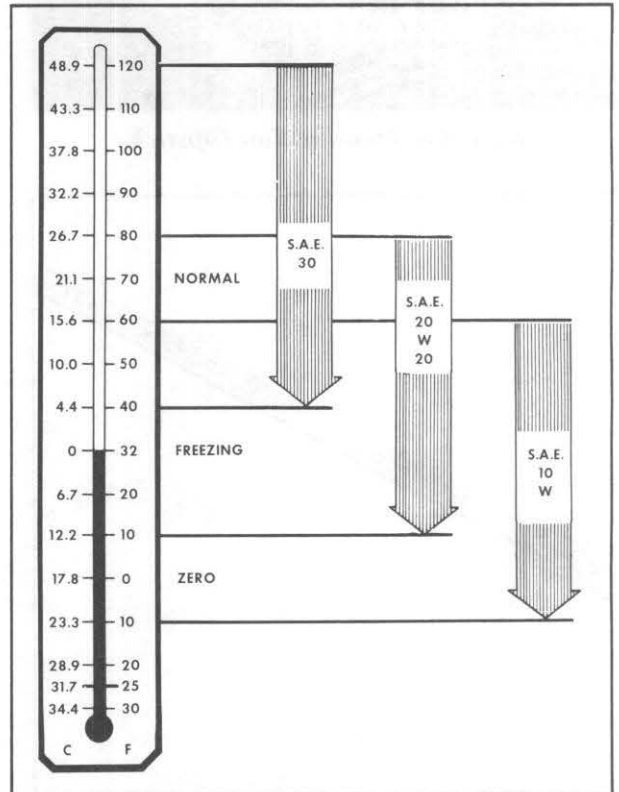

*Engine Oil Viscosity Chart*

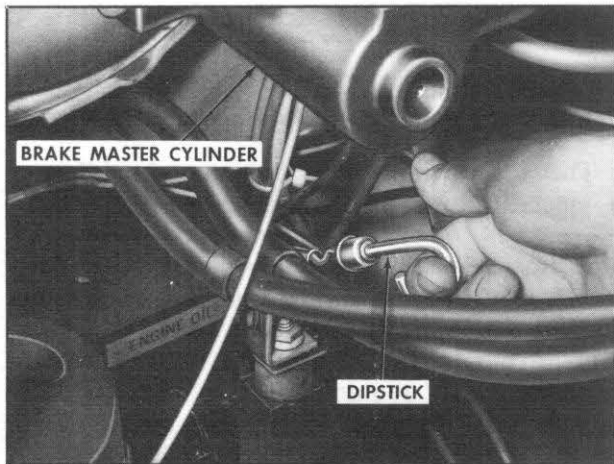

*Removing Engine Oil Dipstick*

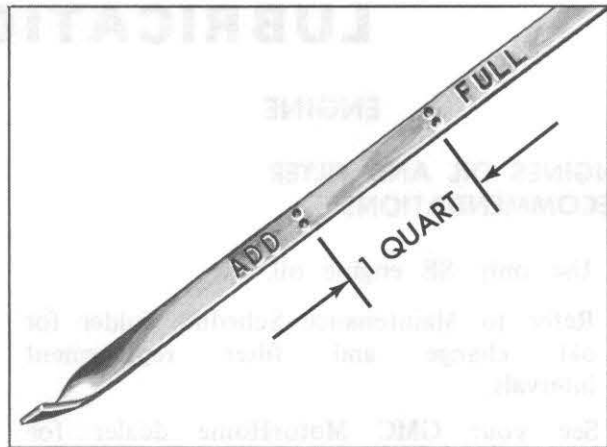

*Engine Oil Dipstick*

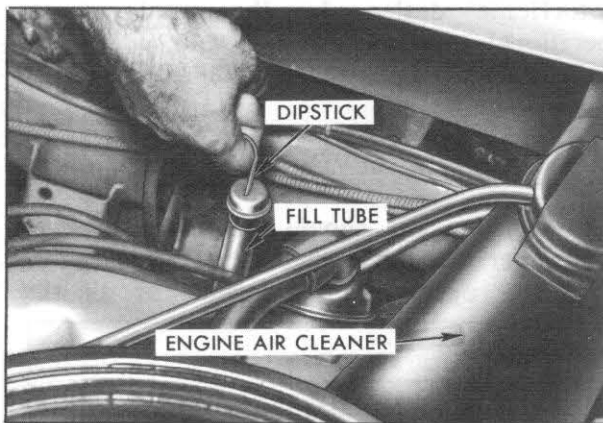

*Removing Transmission Dipstick*

last step in a fuel stop. This will allow the normal oil accumulation in the engine to drain back into the crankcase. To check the level, remove the oil level dipstick located inside the left front access door, wipe it clean and reinsert it fully for accurate reading. The oil level dipstick is marked "FULL" and "ADD." The oil level should be maintained within the margin, neither going above the "FULL" line nor below the "ADD" line. Reseat the dipstick firmly after taking the reading. One (1) quart will raise the oil level from "ADD" to "FULL."

**NOTE:** The oil dipstick is also marked "USE SE ENGINE OIL," as a reminder to use only SE oils.

## TRANSMISSION

The transmission dipstick and fill tube is located under the engine access cover on the left side of the engine.

Use only automatic transmission fluids identified with the mark DEXRON® II. These fluids have been specially formulated and tested for use in your automatic transmission, and are available from your GMC MotorHome dealer or local service station.



*Transmission Dipstick*

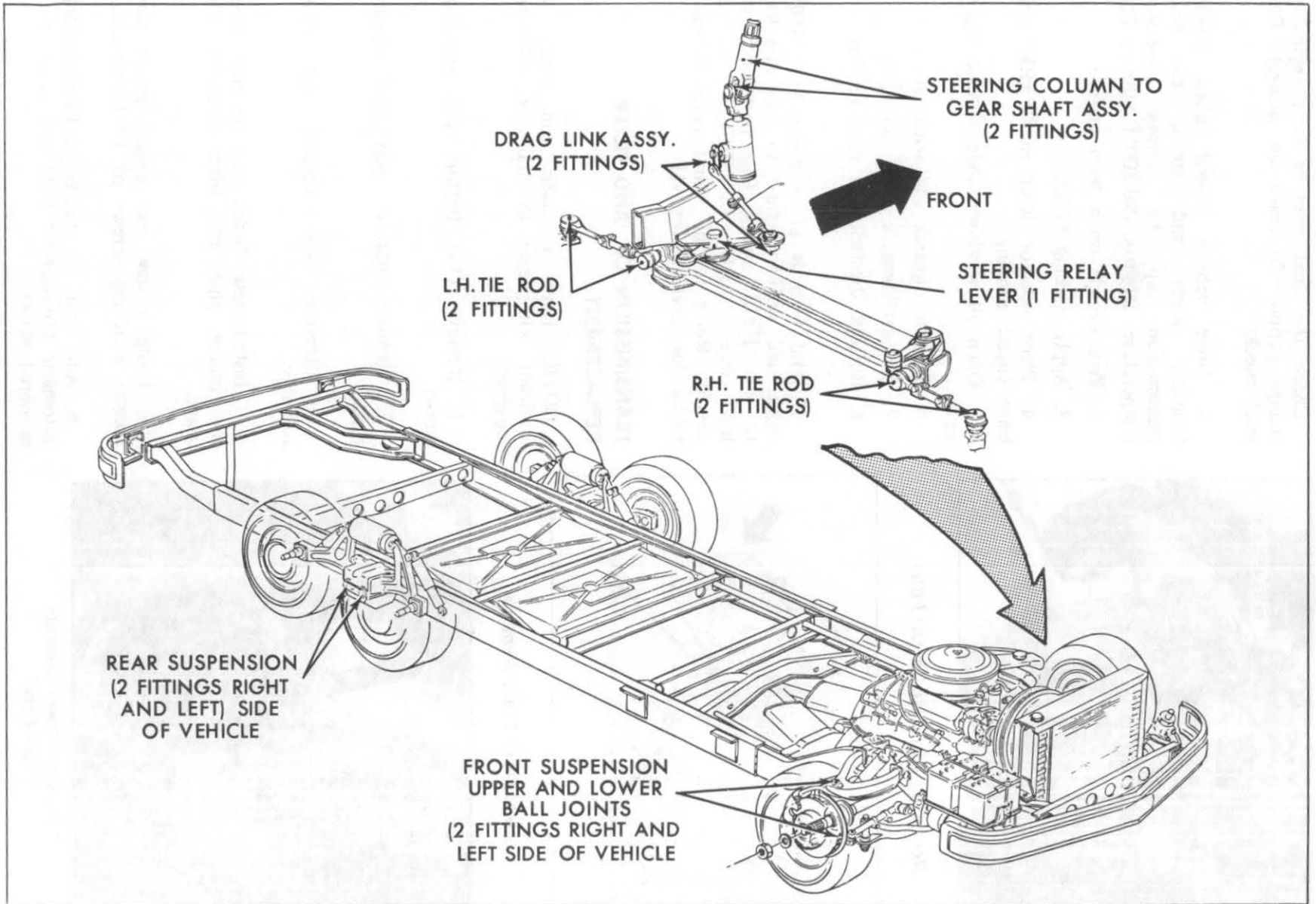

*Location of Chassis Lubrication Fittings*

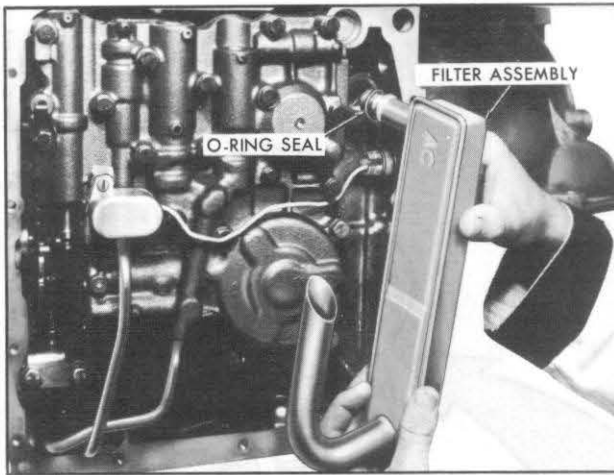

**Replacing Transmission Oil Filter**

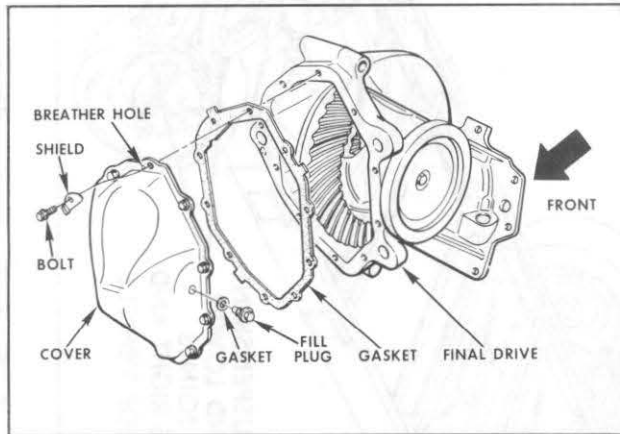

**Final Drive Cover Removal**

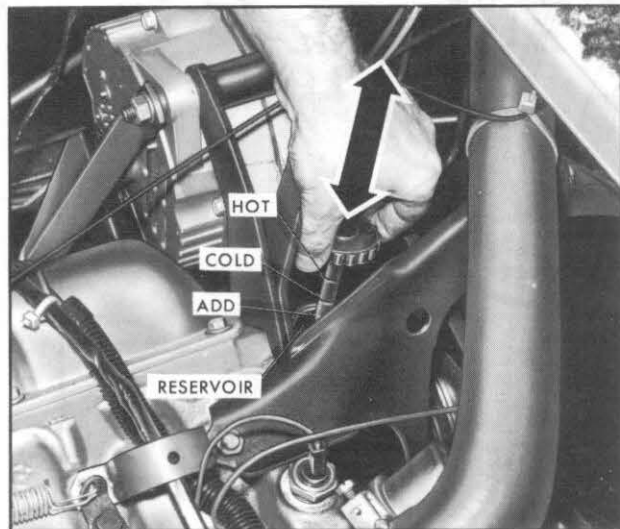

**Checking Power Steering Fluid Level**

Check the fluid level at each engine oil change period. To make an accurate fluid level check:

1. Drive vehicle several miles, making frequent starts and stops, to bring transmission up to normal operating temperature (approx. 190-200° F.) (88-93° C.).
2. Park vehicle on a level surface.
3. Apply parking brake.
4. Place selector lever in "PARK" and leave engine running.
5. Open all windows, then remove engine cover.
6. Remove dipstick and wipe clean.
7. Reinsert dipstick until cap seats.
8. Remove dipstick and note reading.

If fluid level is at or below the "ADD" mark, add sufficient fluid to raise the level to the "FULL" mark. One pint raises the level from "ADD" to "FULL." Do not overfill. Refer to the Maintenance Schedule folder for servicing interval.

### TRANSMISSION OIL AND FILTER REPLACEMENT

**NOTE:** Have a drain pan ready as lubricant will begin to drain as bolts are loosened.

1. Remove (13) bottom pan attaching screws.
2. Remove bottom pan and discard gasket.
3. Remove and discard oil filter assembly.
4. Install new O-ring seal on new filter and intake pipe and filter assembly and install.
5. Using a new pan gasket, install pan. Torque attaching screws to 12 foot-pounds.
6. Add four (4) quarts of DEXRON® II automatic transmission fluid and check fluid as noted above.

## FINAL DRIVE

### FINAL DRIVE LUBRICANT REPLACEMENT

1. Remove (10) cover attaching bolts. Have a drain pan ready as lubricant will begin to drain as bolts are loosened.
2. Remove cover and allow lubricant to drain. Discard old gasket.
3. Using a new cover gasket, install cover. Torque attaching bolts to 24-foot pounds. Shield to be bent over breather hole.
4. Add four pints of recommended lubricant through fill plug hole or fill until lubricant level is at the plug hole. Install fill plug.

**NOTE:** Use SAE 80W or SAE80W-90 GL-5 Gear Lubricant. (For those vehicles operated in Canada, use SAE 80W GL-5 Gear Lubricant.)

## STEERING SYSTEM

### POWER STEERING SYSTEM

Check the fluid level in the power steering pump reservoir at each oil change period. This requires the removal of the engine access cover. The reservoir is located near the Delcotron. Add GM Power Steering Fluid (if GM Power Steering Fluid is not available, DEXRON® II Automatic Transmission Fluid may be used) as necessary to bring level into proper range on the filler cap indicator depending on fluid temperature.

If at operating temperature [approx. 150°F. (66°C.)—hot to the touch] fluid should be between "HOT" and "COLD" marks. If at room temperature [approx. 70°F. (21°C.)] fluid should be between "ADD" and "COLD" marks. The fluid does not require periodic changing.

### STEERING LINKAGE

The steering linkage (tie rods) and suspension should be lubricated, using a Lithium Soap Multi-purpose grease that

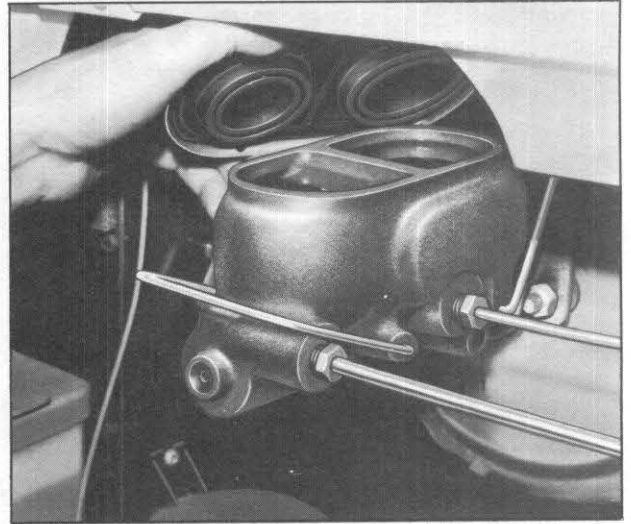

*Checking Brake Master Cylinder*

meets GM Specification 6031-M, at every oil change. Seals should be checked for damage (see Maintenance Schedule folder).

## BRAKE SYSTEM

### BRAKE MASTER CYLINDER

The master cylinder is located behind the left-side access door on the front of the vehicle. The fluid level in the master cylinder should be checked at each oil change. Wipe off the brake cylinder filler cap and unsnap the retainer. A low fluid level in the front brake master cylinder reservoir could be an indicator that the disc brake pads need replacing. The fluid level must be maintained at 1/4-inch below the top of each reservoir with Delco Supreme No. 11 or DOT-3 Brake Fluid or equivalent. When replacing the cap be sure to fasten the retainer securely, taking care not to let dirt enter the reservoirs.

### BLEEDING BRAKES

The need for bleeding brakes is generally indicated by springy, spongy pedal action. Pressure bleeding equipment must be used and a definite bleeding sequence and procedure must be followed. Consult your GMC MotorHome dealer.

# SERVICING DETAILS

## COOLING SYSTEM CARE

### Checking Coolant Level

Open right front access cover. Do not remove radiator cap to check coolant level, but check visually in the "see thru" coolant recovery tank as frequently as necessary. Level should be at the "COLD" mark on the recovery tank when the system is cold; and at the "HOT" mark at normal operating temperature. Add a 50/50 mixture of high-quality ethylene glycol anti-freeze and water to the recovery tank for coolant additions. If frequent additions are required, see your dealer for a cooling system check.

**NOTE:** If the recommended quality antifreeze is used, supplemental inhibitors or additives claiming to provide increased cooling capability are not necessary. They may be detrimental to the efficient operation of the system, and represent an unnecessary operating expense.

### Annual Service

The cooling system should be checked each year as follows:

1. Wash radiator cap and filler neck with clean water.
2. Check coolant for proper level and freeze protection.
3. Test system and radiator cap for proper pressure holding capacity (9 psi). If required, use cap designed by AC for coolant recovery systems and specified for your vehicle.
4. Tighten hose clamps and inspect all hoses. Replace hoses every 24 months, earlier if swollen, checked or otherwise deteriorated.
5. Clean frontal area of radiator core and air conditioning condenser.



*Coolant Recovery Tank (Typical)*

### ENGINE COOLING SYSTEM

The recovery type cooling system is standard on all vehicles covered by this manual. The coolant expands with rising temperature and the overflow is collected in the recovery tank. When the system temperature drops, the coolant is drawn back into the radiator. The cooling system has been filled at the factory with a high-quality, inhibited, year-around coolant that meets the standards of General Motors Specification 1899-M. This coolant solution provides freezing protection to  $-20^{\circ}\text{F}$ . ( $-29^{\circ}\text{C}$ .) ( $-37^{\circ}\text{C}$ . in Canada), and it has formulated to be used without replacement for period specified in Maintenance Schedule folder, providing the proper concentration of coolant is maintained.

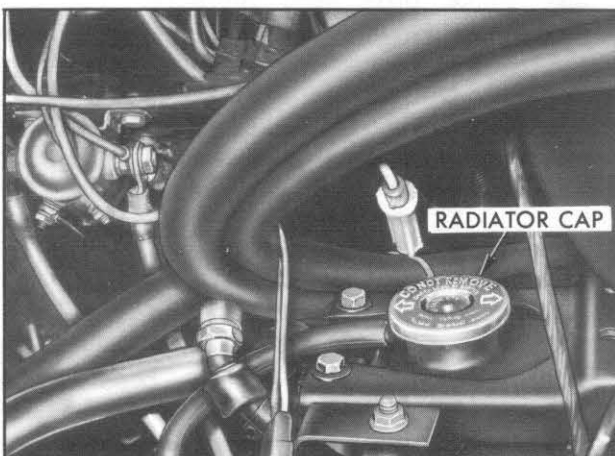

*Location of Radiator Cap*



## Draining and Refilling

The cooling system should be drained, flushed and refilled using the following recommended procedure at intervals specified in the Maintenance Schedule folder.

1. Remove radiator cap when engine is cool:

- Rotate cap slowly counterclockwise to detent (Do not press down while rotating).
- Wait until residual pressure (indicated by a hissing sound) is relieved, then press down on cap and continue to rotate counterclockwise.

### CAUTION

To avoid the danger of being burned, do not remove radiator cap while engine and radiator are still hot because scalding fluid and steam will be blown out under pressure.

2. Run engine, with radiator cap removed, until upper radiator hose is hot (indicates thermostat is open).

3. Stop engine and open radiator drain valve to drain coolant. (Operation may be speeded by removing drain plugs in the block.)

4. Close valve (install block drain plugs, if removed) and add sufficient water to fill system.

5. Repeat steps 1, 2, 3, and 4 a sufficient number of times until the drained liquid is nearly colorless.

6. Allow system to drain completely and then close radiator drain valve tightly. (Install block drain plugs, if removed.)

7. Remove recovery cap leaving hoses in place. Remove coolant recovery tank,

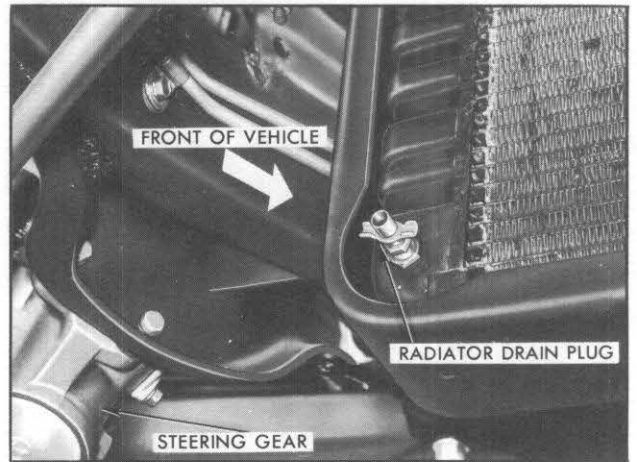

### Radiator Drain Plug

empty fluid, scrub and clean bottom and sides of tank with detergent and water, flush well with clean water, drain and reinstall.

8. Add sufficient ethylene glycol coolant, meeting GM specification 1899-M, to provide the required freezing and corrosion protection—at least a 50 percent solution (-34°F.) (-37°C.). Fill radiator to the base of the radiator filler neck and bring level of coolant in the recovery tank to the “FULL HOT” mark. Reinstall recovery tank cap.

9. Run engine, with radiator cap removed, until radiator upper hose becomes hot.

10. With engine idling, add coolant to radiator until level reaches bottom of filler neck; install cap making certain arrows line up with overflow tube.

## Owner Responsibility

It is the owner's responsibility to:

- Maintain cooling system freeze protection at -20°F. (-29°C.) or below to ensure protection against corrosion and loss of coolant from boiling, even though freezing temperatures are not expected.

- Add ethylene glycol base coolant that meets GM Specification 1899-M when coolant additions are required because of coolant loss or to provide additional protection against freezing at temperatures lower than  $-20^{\circ}\text{F}$  ( $-29^{\circ}\text{C}$ ) ( $-37^{\circ}\text{C}$  in Canada).

**NOTE:** Alcohol or methanol base coolants or plain water are not recommended for your vehicle at any time.

## THERMOSTAT

The cooling system is protected and controlled by a thermostat installed in the engine coolant outlet to maintain a satisfactory operating temperature of the engine. This thermostat is designed for continuous use through both winter and summer and need not be changed seasonally. When replacement is necessary, Delco parts are recommended.

## ENGINE FUEL SYSTEM

### FUEL REQUIREMENTS

Your vehicle's engine is designed to operate on unleaded gasoline which minimizes spark plug fouling and emission control system deterioration. Regular grade leaded gasoline should be used only when needed to eliminate knock, a metallic rapping noise generated during the combustion process. The engine does not require Premium grade fuel. Thereafter, its use would be an unnecessary additional expense. If knocking persists, consult your authorized dealer. Continuous or excessive knocking may result in engine damage and constitutes misuse of the engine for which the manufacturing division is not responsible under terms of the new vehicle warranty.

Use a gasoline of at least 87 average octane number (Research octane plus Motor octane divided by two.) The gasoline should have a Research octane number of at least 91, and a Motor octane number of at least 83. The average octane number of each gasoline is posted on service station pumps in accordance with regulations issued by the Federal Energy Administration.

## FUEL SYSTEM

The vehicle has two gasoline tanks of approximately 25 gallons each and fuel switching device (see "FUEL SELECTOR" switch) which allows the driver to switch from the main tank (when empty) to the auxiliary tank.

The gasoline fuel filler compartment is located on the left side of the vehicle, directly under the driver's window.

### CAUTION

**It is important that all pilot lights be turned off and open flames kept away when filling the fuel system to help reduce fire hazard.**

**GAS CAP**—The cap is equipped with a double set of locking tangs.

To Remove:

- Rotate cap one-half turn counterclockwise to clear the first set of tanks from the slots inside the filler neck. This will allow any residual pressure to escape.
- Pull the cap outward and rotate one-quarter turn counterclockwise to clear second set of tangs. Then remove the cap.
- To install, reverse this procedure.

**NOTE:** If the gas cap requires a replacement, only a cap with the same features should be used. Failure to use the correct cap can result in a serious malfunction of the system. Correct replacement caps may be obtained from your GMC MotorHome dealer.

**IMPORTANT:** If automatic gasoline pump nozzle shuts off before both fuel tanks are full, it is recommended that a delay of approximately 1 minute be held prior to continuation of filling tanks. Automatic nozzle should then be adjusted for a slower fuel feed, to fill remainder of tanks.

## CARBURETOR

To obtain maximum engine performance and fuel economy, carburetor idle speeds should be checked as recommended in the Maintenance Schedule folder. If the engine stalls, idles too fast or slow, or idles roughly, the following adjustments should be performed. However, if the above symptoms persist it is recommended the vehicle be taken to a GMC MotorHome dealer.

**NOTE:** Refer to Tune-up label on engine for correct specifications.

### Fuel Filter

To replace carburetor filter, disconnect fuel line, remove filter nut, gasket, filter, and spring. Install spring and element (open end of filter facing toward filter nut). Install gasket; tighten nut to 18 foot-pounds torque.

**IMPORTANT:** Tightening fuel inlet nut beyond specified torque can damage nylon gasket.

### ENGINE AIR CLEANER

The air cleaner is a disposable type element. Replace the element as specified in the Maintenance Schedule folder. Do not wash, oil, or clean with air hose. The air cleaner will require more frequent service under dusty conditions. Your GMC MotorHome dealer can advise you on the proper interval. When replacement is necessary, an AC ACron air filter element is recommended.

#### CAUTION

DO NOT remove the engine air cleaner unless temporary removal is necessary during repair or maintenance of the vehicle. When the air cleaner is removed, backfiring can cause fire in the engine compartment.

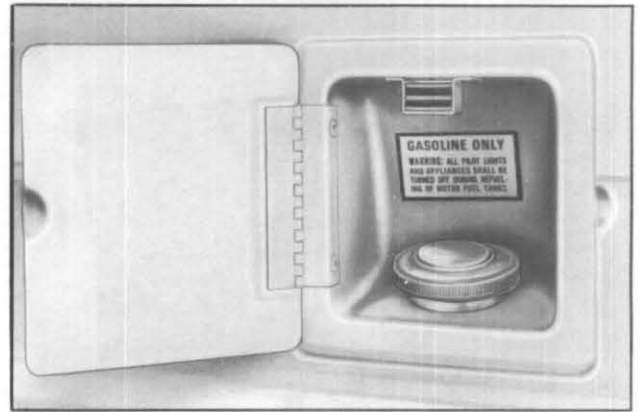

*Gasoline Fuel Filler Compartment*

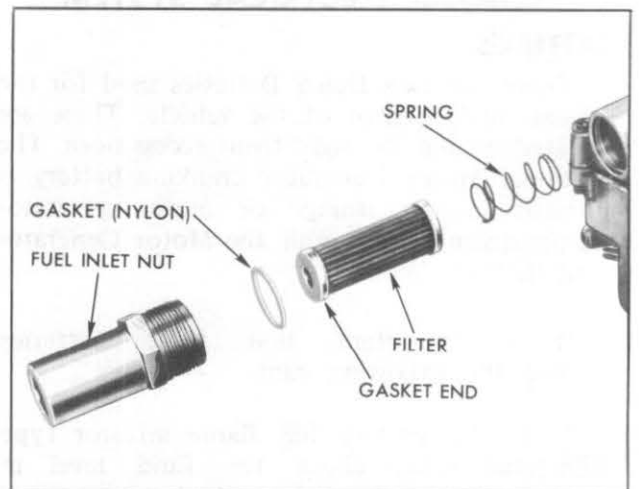

*Fuel Filter Components*



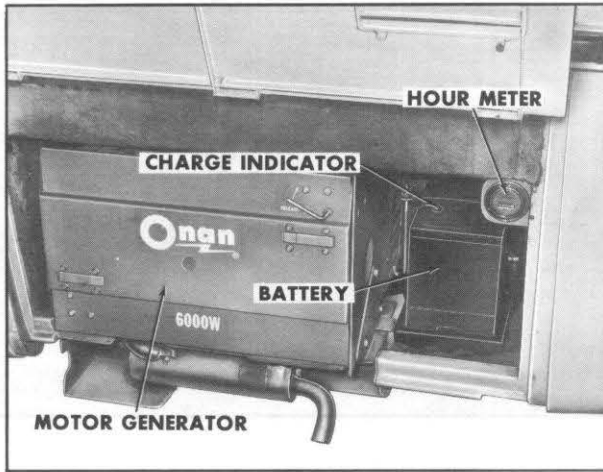

*Motor Generator Compartment*

## CHASSIS ELECTRICAL SYSTEM

### BATTERIES

There are two Delco Batteries used for the chassis and interior of the vehicle. These are located behind the right front access door. The optional Motor Generator cranking battery is located in the storage or motor generator compartment along with the Motor Generator and the hour meter.

It is important that these batteries receive the following care:

1. If the battery has flame arrestor type filler/vent caps, check the fluid level in each cell at each engine oil change interval and more often in hot weather. (To do this it may be helpful to use a small hand mirror.) Add only colorless, odorless

drinking water or distilled water to bring the level to the split-ring in the filler opening. DO NOT OVERFILL.

2. The batteries may be maintenance-free type batteries, identified by the absence of vent plugs. Water never needs to be added to the maintenance-free batteries. A charge indicator in the cover of the battery indicates the state of charge. Check the charge indicator at each engine oil change interval. (A small hand mirror may be helpful in reading the indicator.)

- If the charge indicator is dark and has a green dot in the center, the battery is sufficiently charged.
- If the charge indicator is dark and a green dot is not visible, have your GMC MotorHome dealer charge the battery.
- If the charge indicator appears light, the battery must be replaced. If the battery fails prematurely and exhibits a light indicator condition, have your dealer check the charging system of the vehicle.

### CAUTION

To avoid explosion hazard, NEVER attempt to charge or jump start a maintenance free battery which exhibits a light indicator condition. Departures from this procedure could result in serious personal injury or property damage. For additional details refer to "JUMP STARTING" earlier in this manual.

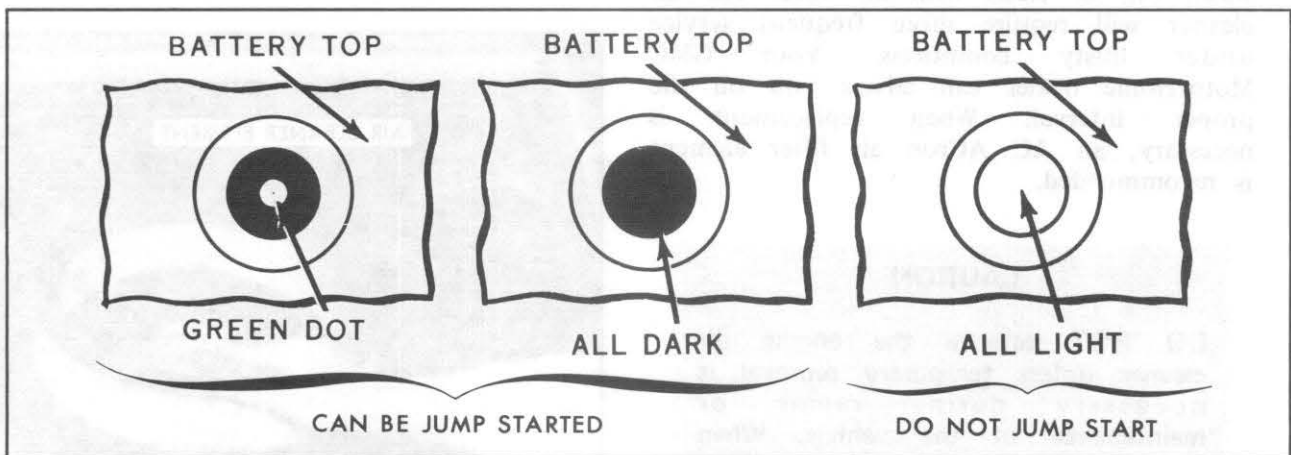

*Charge Indicator Conditions (Maintenance-Free Battery)*

3. Keep your batteries, battery cable terminals, and battery hold-down brackets clean. They should be cleaned every 12,000 miles or once a year. Use a brush and a solution of ammonia and water or baking soda and water. Flush off with clear water. After cleaning apply petroleum jelly to petrolatum to battery cable terminals to help retard corrosion.

4. If battery performance becomes questionable see your dealer.

For full voltage requirements a Delco Battery is recommended at replacement time.

### CAUTION

Never expose battery to open flame or electric spark—chemical action in the battery generates hydrogen gas which is flammable and explosive. Do not allow battery fluid to contact eyes, skin, fabrics, or painted surfaces—fluid is a corrosive sulfuric acid solution which could cause serious personal injury or property damage. **FLUSH ANY CONTACTED AREA WITH WATER IMMEDIATELY AND THOROUGHLY. WEAR EYE PROTECTION WHEN WORKING ON OR NEAR BATTERY.** Remove rings, metal watchbands and other metal jewelry before working on or around a battery. Be careful in using metal tools and equipment. If such metals should contact the positive battery terminal (or metal in contact with it) and any other metal on the vehicle, a short circuit may occur which could cause personal injury. Batteries and battery acid should always be kept out of the reach of children.

For "Battery Jump Starting Procedure" see IN CASE OF EMERGENCY section.

## DISTRIBUTOR

Distributor maintenance, which is the owner's responsibility, includes regular examination of the distributor cap for cracks, checking condition of ignition wires, and proper ignition timing at specified intervals. Refer to the Maintenance Schedule folder for additional information.

**NOTE:** Refer to Tune-up label on engine for correct specifications.

## SPARK PLUGS

The frequency of spark plug service intervals is explained in the Maintenance Schedule folder. Servicing is the owner's responsibility. Before removing plugs, clean plug wells thoroughly, clean the threads and seats in the cylinder heads to assure proper seating and heat transfer.

## HEADLIGHTS

Make a headlight beam adjustment check a regular part of your "Safety Maintenance" program. Sealed-Beam units are No. 6014 which are equipped with ground guide points for the use of a mechanical aiming device. Your authorized dealer is best qualified to adjust your headlights.

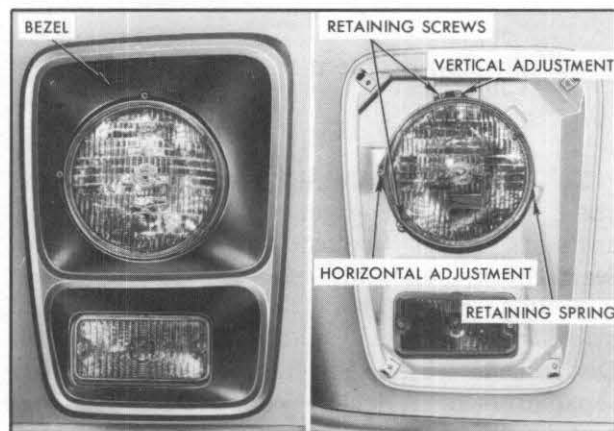

*Headlight Replacement*

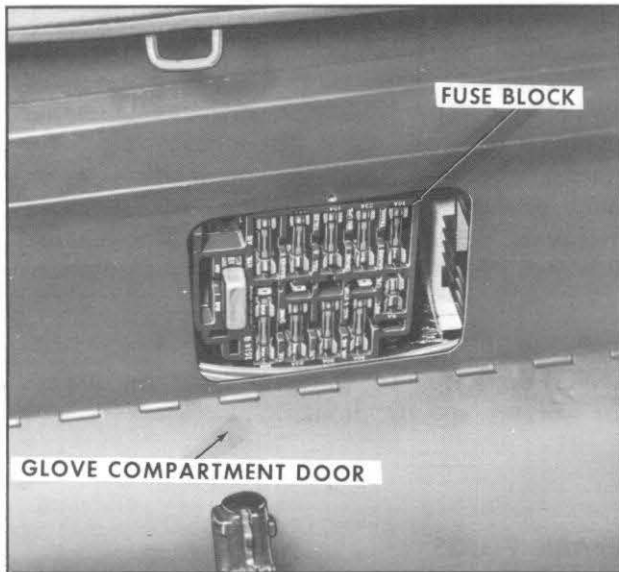

*Chassis Fuse Block*

### Headlight Beam Adjustment

**NOTE:** Cutouts in headlight bezel permit access to adjustment screws.

Headlights should be adjusted properly. The top adjusting screw provides vertical adjustment and the side adjusting screw provides horizontal adjustment. Headlights should not have to be adjusted after replacing Sealed-Beam unit, providing headlights were in proper adjustment before replacement and adjusting screws were not disturbed during replacement.

### Headlight Replacement

To replace a Sealed-Beam unit, remove bezel. Then disengage the tension spring using a stiff hooked tool. Rotate the Sealed-Beam assembly slightly to disengage mounting ring slots from groove of each adjusting screw, then pull forward. Disconnect wiring at the base of unit and separate the Sealed-Beam assembly by removing the two retaining screws. Install Sealed-Beam unit in reverse order of removal.

## EXTERIOR LIGHTS

All exterior lights can be easily replaced by removing lens, pushing bulb in slightly and turning counterclockwise, except side marker lights which are simply pressed in. Then, with new bulb, reverse procedure.

## CHASSIS FUSES, FUSIBLE LINKS, CIRCUIT BREAKERS

The wiring circuits in your vehicle are designed to be protected from short circuits by a combination of fuses, circuit breakers, and fusible thermal links in the wiring itself. This helps to reduce the hazard of electrically-caused fires in the vehicle.

The fuse and circuit breaker block is located behind an access cover in the glove compartment. All chassis circuits are protected by fuses or circuit breakers located here except:

- **HEATER BLOWER**—Which has a fusible link built into harness located behind the right access door near the heater blower relay.
- **HEADLAMP CIRCUITS**—Are protected by a circuit breaker in the main light switch. An electrical overload in the light circuit will cause the lights to go on and off or in some cases to remain off. If this condition develops, have the wiring circuits checked immediately.

Circuit breakers of remote reset type can be reset only after turning the affected circuit control switch "OFF" for approximately 40 seconds, or by removing the breaker from clips for this period of time.

### CAUTION

**Do not touch body of any installed breaker of this type with bare hands; if circuit should happen to be shorted or overloaded—the breaker body could be hot and cause a burn.**

A replaceable fuse link is located at the battery pickup junction block behind the right access door. If an overload should occur, this link is designed to fail (open circuit) preventing damage to the main wiring harness. Another link of the same wire gauge and length must be installed in its place in the event of failures.

**IMPORTANT:** When replacing fuse or circuit breaker, make sure replacement is of same number as marked on block.

## TURN SIGNAL HAZARD WARNING FLASHER

The turn signals and the hazard warning system both operate with the same flasher. This flasher is clipped behind the dashboard just to the right of the steering column.

## WHEELS AND TIRES

### TIRES

The factory installed tires on your vehicle are designed to provide the best all-around performance for normal vehicle operation. When inflated as recommended on the "Tire Pressure Placard," located on the glove compartment door of your vehicle, the tires have the load carrying capacity to operate satisfactorily at all normal highway speeds.

### Tire Care

Tires should be checked regularly for proper inflation pressure, wear, and damage. The following information will assist you in properly caring for your tires.

### Inflation Pressure

Tire inflation pressures listed on the tire placard have been selected to provide the best tire life, riding comfort and handling stability for normal driving conditions.

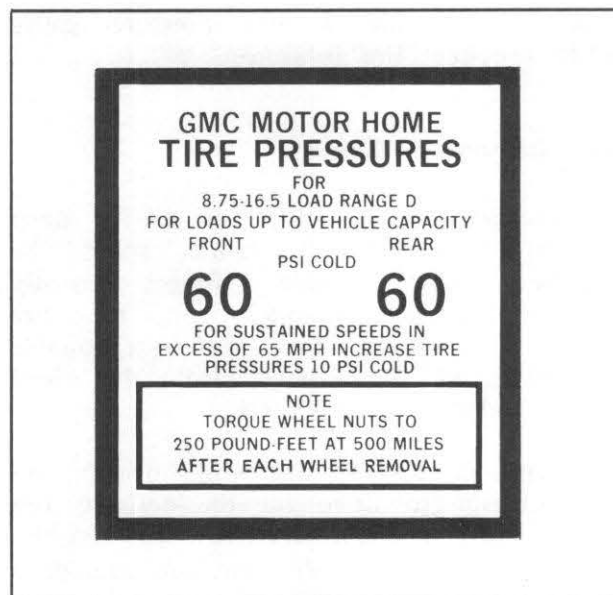

*Tire Pressure Placard*

The use of improper tire inflation pressures can adversely affect tire life and vehicle performance. Too little air pressure can result in excessive tire heat, abnormal tire wear, adverse vehicle handling and reduced fuel economy. Too much air pressure can result in abnormal tire wear, adverse vehicle ride and handling, and increased susceptibility to damage by road impacts.

Tire pressures should be checked at least once a month (and preferably more often) or before long trips or when heavily loaded. The following points should be observed when checking and setting tire pressures.

1. Cold tire pressure ratings are applicable when a vehicle has been inoperative for 3 hours, or more, or driven less than one mile.
2. Tire inflation pressure may increase as much as 6 psi when hot (after vehicle has been driven 10 miles or at speeds of more than 60 MPH). Do not "bleed" or reduce pressures when tires are hot from driving.
3. For continuous high speed operation (over 65 MPH), increase tire inflation pressure to 70 psi.

4. Always use a tire pressure gauge when checking tire pressure.

### Tire Damage & Repair

Tires with cuts, splits or cracks deep enough to expose the fabric, should be removed from service. Bulges usually indicate internal damage, and the tire should be removed. Tires with questionable damage should be removed from the wheel and examined by an expert.

If an air loss occurs while driving, do not attempt to drive on the deflated tire more than is necessary to stop safely. Driving even a short distance can damage a tire beyond repair.

Temporary repairs, such as "blowout" patches or any repair made from the outside of the tire should not be made except in emergencies. Such "stop-gap" devices as plugs and aerosol-type sealants are good for not more than 100 miles of driving at speeds not over 50 MPH. A permanent vulcanized repair, plug or patch applied from inside the tire, should be made as soon as possible. Also, the installation of an inner tube in a damaged tubless tire is not a recommended repair procedure.

### Replacement Tires

When replacing tires, only the size (8.75-16.5), load range ("D"), construction type bias-ply steel belted) are recommended for installation on the vehicle.

**IMPORTANT:** Radial tires are not recommended for installation on the vehicle.

Use of any other tire may seriously affect ride, handling, speedometer/odometer calibration, vehicle ground clearance and tire clearance to the body and chassis. The following also should be considered when replacing tires:

- To achieve best all-around vehicle performance, bias-ply and bias-ply steel belted tires should not be mixed on the same vehicle.
- It is recommended that new tires be installed in pairs opposite each other (preferably the front wheels).
- When replacing only one tire, it should be paired with the tire having the least wear, to equalize braking traction.

### Replacement Wheels

Wheels must be replaced if they become bent, are heavily rusted, if the lug nuts won't stay tight, or if they leak air. Straightening bent wheels or using inner tubes in leaking wheels are not recommended repair procedures.

When replacing wheels for any reason, care should be taken to insure that the wheels are equivalent to those removed in load capacity, diameter, rim width, and offset. Correct replacement wheels can be obtained from your GMC MotorHome dealer.

Use of any other size or type wheel may adversely affect wheel and wheel bearing life, brake cooling and stopping ability, headlamp aim, speedometer-odometer accuracy, bumper height, vehicle ground clearance and tire clearance to the body and chassis.

The use of used wheels is also not recommended; if they have been run overloaded or under other severe operating conditions for extended periods, the wheel's life may have been greatly shortened.

### Tire Warranty

Tires are warranted by the tire manufacturers as covered in the New Vehicle Warranty folder.



## Tire Traction

A decrease in driving, cornering, and braking traction occurs when water, snow, ice, gravel, or other material is on the road surface. Driving practices and vehicle speed should be adjusted to the road conditions.

When driving on wet or slushy roads, it is possible for a wedge of water to build up between the tire and road surface. This phenomenon, known as hydroplaning, may cause partial or complete loss of traction, which adversely affects vehicle control and stopping ability. To reduce the possibility of traction loss, the following precautions should be observed:

1. Slow down during rain-storms or when roads are slushy.
2. Slow down if road has standing water or puddles.
3. Replace tires when tread wear indicators are visible.
4. Keep tires properly inflated.

## Snow Tires

If the vehicle is expected to encounter muddy or snowy driving conditions it is recommended that front driving wheels be equipped with mud and snow type tires.

If you equip your vehicle with mud and snow tires, they should be of the same size, load range, and construction as original equipment tires. It is recommended that vehicle speeds be limited to a maximum of 75 mph if mud and snow tires are installed.

## Tire Wear and Rotation

Uneven or abnormal tire wear is usually the result of incorrect inflation pressure, improper wheel alignment, wheels being out-of-balance, or poor driving habits. Under-inflation, over-inflation, incorrect toe or camber and fast cornering produce different types of abnormal wear which can be diagnosed by your dealer.

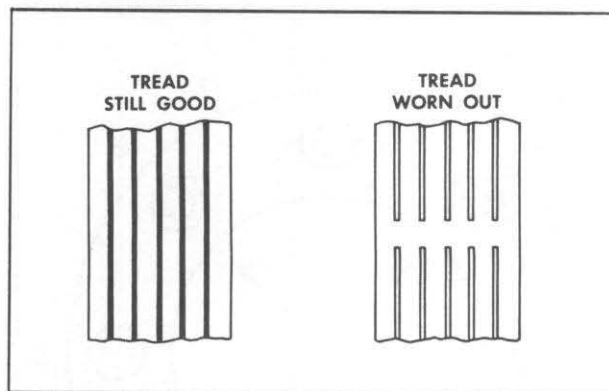

*Tire Tread Wear Indicator*

To equalize wear it is recommended that the tires be rotated every 6,000 miles (or sooner if irregular wear develops) as shown.

**NOTE:** It is recommended that disc brake pads be inspected for wear whenever tires are rotated.

The original equipment tires incorporate built-in tread wear indicators to assist you in determining when your tires have worn to the point of needing replacement. These indicators appear as 1/2-inch wide bands when tire tread depth is 1/16-inch or less. When the indicators appear in two or more adjacent grooves, tire replacement due to tread wear is recommended.

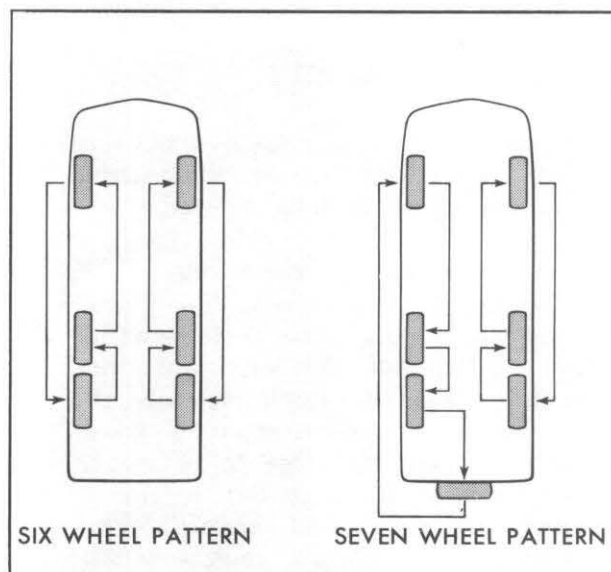

*Tire Rotation Diagram*

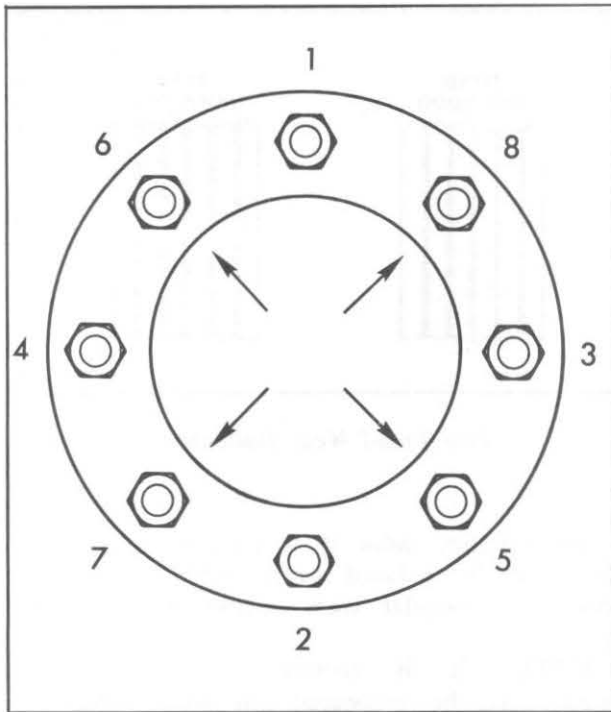

*Wheel Stud Tightening Sequence*

### Tightening Wheel Stud Nuts

When the vehicle is new or after wheels have been replaced, it is the owner's responsibility to check wheel stud nuts at 500 miles and after every wheel removal thereafter. Nuts should be tightened to 250 foot-pounds torque in sequence shown.

#### CAUTION

If any wheel experiences a single stud failure caused by a loose-running wheel, all wheel studs should be replaced.

A loose-running wheel may cause only one stud to break, but several more studs may become fatigued to the point of failure, but not actually breaking. Replacing only the broken stud and remounting wheel will then set the stage for a second and possible more serious failure. If holes in the wheel have become elongated or enlarged, replace wheel.

Tighten wheel stud nuts as follows:

1. Install all nuts loosely, then finger-tighten only the nuts marked by arrows.

2. Tighten all nuts to specified torque in sequence illustrated. Never use oil or grease on studs or nuts.

See IN CASE OF EMERGENCY section for procedure used to change tire.

### FRONT WHEEL BEARING

The front wheel bearings should be cleaned, inspected and repacked at intervals specified in the Maintenance Schedule folder. This operation requires special tools and should be performed by your GMC MotorHome service outlet.

### REAR WHEEL BEARING ADJUSTMENT

A periodic rear wheel bearing repack is required as indicated in Maintenance Schedule folder. These bearings should be cleaned and repacked with Lithium Soap Multi-Purpose Grease Meeting GM Specification 6031-M or equivalent.

The adjustment of the bearing must be done with the wheel off the floor, and rotating the wheel while tightening nut. At this time make the torque readings as follows:

1. Tighten adjusting nut with a torque wrench to 25-30 foot-pounds with wheel rotating to ensure that all parts are properly seated and threads are free.

2. Back off nut one-half turn. Re-tighten nut finger-tight.

3. If unable to install cotter pin at finger-tight position, back off one slot, then secure with cotter pin.

4. End play should be .001" to .005". Also at this interval the rear suspension control arms should be lubricated. This is accomplished at the fittings between the rear wheels.

## FRONT SUSPENSION

The front suspension consists of control arms, stabilizer bar, shock absorbers and a right and left torsion bar. The front suspension components are designed to provide satisfactory service, ride, and handling if not overloaded and adjusted to specified vehicle front end ride height.

No maintenance other than lubrication is normally required. Refer to lubrication information given earlier in this section for intervals and lubrication points.

The front of the torsion bar is attached to the lower control arm. The rear of the torsion bar is mounted into an adjustable arm. The front ride height is controlled by this adjustment.

The simplest way to adjust is to move arm slightly to achieve ride height and drive unit a few blocks so as to overcome delaying action.

**NOTE:** Ride height is measured from top of elongated slot in frame rail to ground level. Tire inflation should be checked prior to making any ride height adjustment.

Ride height should be adjusted by raising vehicle to relieve strain on adjusting bolt. Lubricate adjusting bolt with chassis grease. Adjustment is made by repositioning adjusting bolt to wind-up and unwind

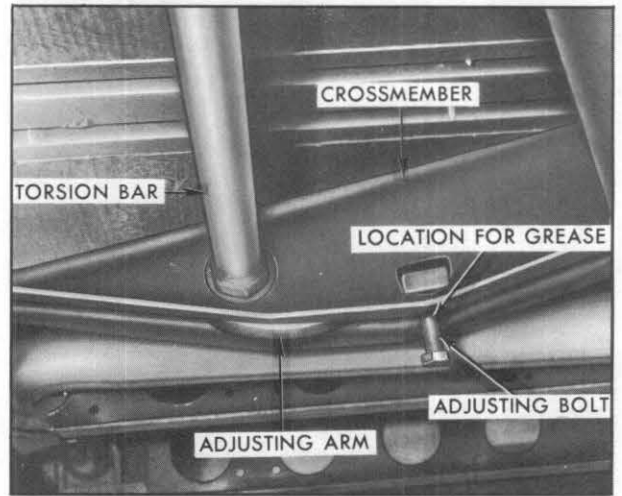

*Location—Front Ride Height Adjustment*

torsion bar. Whenever ride height is changed, be sure to check front end alignment and readjust if necessary.

**NOTE:** Overloading and incorrect ride height can create serious problems and shorten the service life of the vehicle. Adjust front suspension ride height to specifications shown.

## REAR SUSPENSION

The rear suspension consists of control arms, mounting brackets, air bellows, shock absorbers, air compressor, air reserve tank, and height control valves. The system operates automatically as load varies, and is designed to maintain a constant frame height.

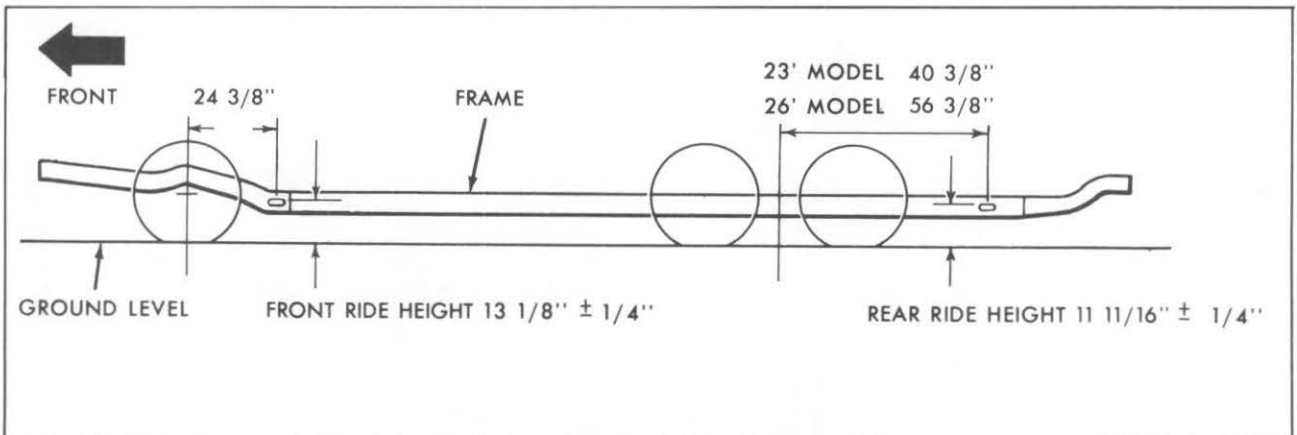

*Checking Vehicle Ride Height*

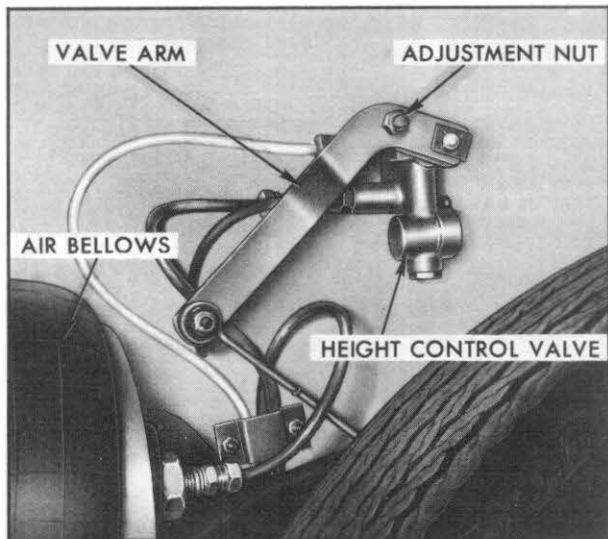

#### Location—Rear Ride Height Adjustment

**NOTE:** Ride height is measured from top of elongated slot in frame rail to ground level. Tire inflation should be checked prior to making any ride height adjustments.

The rear suspension can be manually adjusted for variations in load distribution. Adjustment is made at the adjustment nut on the height control valve arm.

#### MAINTENANCE

1. Drain air reservoir under front of vehicle to remove moisture.
2. The air compressor must periodically have the air filter washed with soap and

water solution or replaced. Filter should be serviced at intervals specified in Maintenance Schedule folder.

**NOTE:** Occasionally check air bellows to see if they are caked with accumulated mud deposits. If deposits are present remove them from air bellows.

#### UNDERBODY MAINTENANCE

The effects of salt and other corrosive materials used for ice and snow removal and dust control can result in accelerated rusting and deterioration of underbody components such as brake and fuel lines, frame, exhaust system, brackets, parking brake cables. These corrosive effects, however, can be reduced by periodic flushing of the underbody with plain water. In geographic areas having a heavy concentration of such corrosive materials, it is recommended that the complete underbody be inspected and flushed at least once each year, preferably after a winter's exposure. Particular attention should be given to cleaning out underbody members where dirt and other foreign materials may have collected.

If desired, your Motor Home dealer can perform this service for you. In addition, he can provide recommendations on undercoating materials which will help protect your vehicle from corrosion. (See "Undercoating" in APPEARANCE CARE section.)



## SECTION 6

# SPECIFICATIONS, OWNER ASSISTANCE, INDEX, GAS STATION INFORMATION

### VEHICLE IDENTIFICATION NUMBER

In order that your vehicle may be specifically identified as to manufacturer, engine type, year designator, etc., refer to chart below.

(TYPICAL IDENTIFICATION NUMBER TZE336V100053)

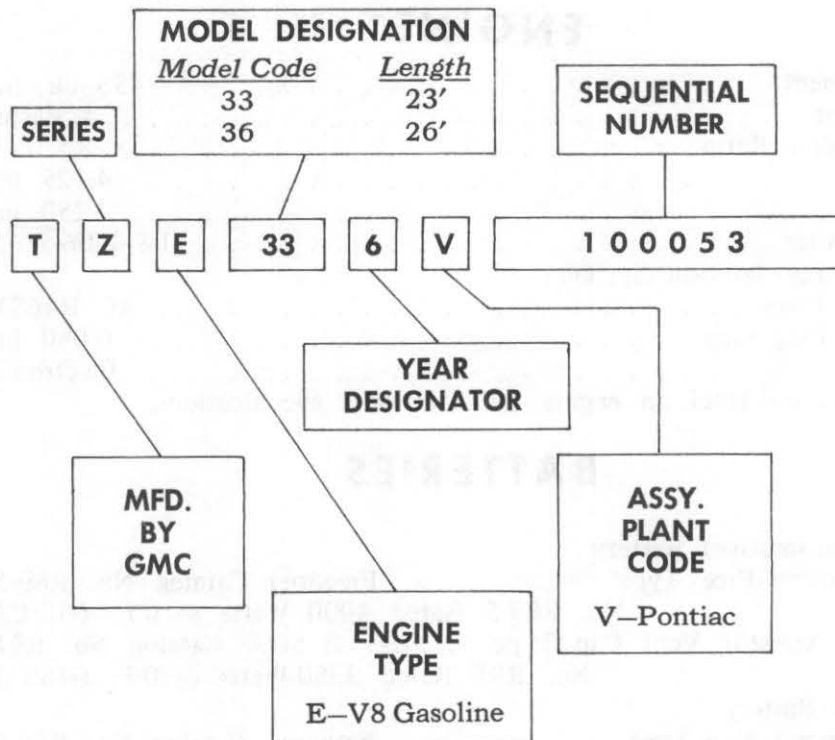

*Vehicle Identification Number*

## VEHICLE DIMENSIONS

Track . . . . .	Front—75.28 in.
	Rear—82.12 in.
Wheelbase . . . . .	23' Model . . . 140 In.
	26' Model . . . 160 in.
Length (Including optional spare tire) . . . . .	23' Model . . . 23 ft.-9in.
	26' Model . . . 26 ft.-9in.
Width . . . . .	96 in.
Height . . . . .	8 ft.-1 in.
Interior Ceiling Height . . . . .	76 in.

## CAPACITIES

Fuel System . . . . .	Two, 25 Gal. Tanks
Cooling System . . . . .	21 Qts.
Engine Oil . . . . .	5 Qts. (Including Filter 6 Qts.)
Turbo Hydramatic . . . . .	Drain & Refill 4 Qts.
	After Complete Overhaul 12 Qts.
Final Drive (Differential) . . . . .	4 Pts.
Power Steering Pump . . . . .	1/2 Qt.
Power Steering System . . . . .	1 1/2 Qt.

## ENGINE\*

Displacement . . . . .	455 cu. in.
Carburetor . . . . .	4 Barrel
Compression Ratio . . . . .	8.5 : 1
Bore . . . . .	4.125 in.
Stroke . . . . .	4.250 in.
Firing Order . . . . .	1-8-4-3-6-5-7-2
High Energy Ignition System	
Spark Plugs . . . . .	AC R46SX
Spark Plug Gap . . . . .	0.080 in.
Dwell . . . . .	Electronic

\*See Tune-up label on engine for additional specifications.

## BATTERIES

Main (Automotive) Battery	
Maintenance-Free Type . . . . .	Freedom Catalog No. R89-5
	No. R89-5 Rated 4000 Watts @ 0°F. (-18°C.)
Flame Arrestor Vent Cap Type . . . . .	E 5000 Catalog No. R91
	No. R91 Rated 3350 Watts @ 0°F. (-18°C.)
Auxiliary Battery	
Maintenance-Free Type . . . . .	Freedom Catalog No. R89-5
	No. R89-5 Rated 4000 Watts @ 0° F. (-18° C.)
Flame Arrestor Vent Cap Type . . . . .	E 5000 Catalog No. R91
	No. R91 Rated 3350 Watts @ 0° F. (-18°C.)
Motor Generator (Optional) Battery	
Maintenance-Free Type . . . . .	Freedom Catalog No. R 85-5
	No. R85-5 Rated 3200 Watts at 0°F. (-18°C.)

## MISCELLANEOUS

Radiator cap (pressure opening) . . . . .	9 PSI
	AC Type RC32
Thermostat . . . . .	195°F.

## TIRE INFORMATION

SEE "Wheels and Tires" in the SERVICE AND MAINTENANCE section of this manual and the tire placard on the glove box door.

## FILTER RECOMMENDATIONS

Engine Air Cleaner . . . . .	AC Type A212CW
Engine Oil . . . . .	AC Type PF30
Transmission Oil . . . . .	AC Type PF160
Engine Fuel . . . . .	AC Type GF441
PCV Valve . . . . .	AC Type CV679C
Carbon Canister . . . . .	GM Part 7026014

## FRONT END ALIGNMENT

Caster (Degrees)* . . . . .	+2° ±1/2°
Camber (Degrees)** . . . . .	R.H. +1/2° ± 1/4° L.H. + 3/4° ± 1/4°
Toe-In (Inches) . . . . .	-1/8 ±1/8

\*L.H. and R.H. must be within 1/2°.

\*\*L.H. camber must be more positive (+) than R.H. camber.

# VEHICLE FUSES AND CIRCUIT BREAKERS

The following fuses are located in the fuse block behind the glove box in the dash. Do not use fuses or higher amperage rating than those specified below—or property damage may result.

Usage	Name on Fuse Block	Fuse Type
Auxiliary Battery Switch, Radio, Tape Player	Aux. Bat.-Radio	AGC-10
Heater Controls, Air Conditioner	Htr.-A/C	AGC-25
Side Marker Lights, I.D. & Clearance Lights, Tail Lights, Dome Lights, License Light	Tail-Dome	SFE-20A
Stop Lights, Hazard Warning Lights, Turn Signal Lights	Dir. Sig.-Haz. & Stop	SFE-20A
Windshield Washers	Washer	AGC-10
Cigar-Cigarette Lighter	Ltr.	SFE-20A
Cruise Control, Back-up Lights	Cruise-B/U Lps.	SFE-20A
Transmission Control, Parking Brake Light, Gauges	Gauges-Trans.	SFE-10A
Instrument Lamps	Inst. Lps.	SFE-4A
Warning Tell-Tale Lights	Tell-Tales	AGC-10

The following circuits employ circuit breakers or have fuses located as indicated:

Headlight Circuit Breaker . . . . . Built Into Light Switch

Heater Blower Fusible Link . . . . . Built Into Line At  
Right Access Door Near  
Heater Blower Relay

Warning & Signal Flasher GM No. 673499 . . . . . In Clip Behind  
Instrument Panel

Vehicle Trouble Light AGC-10 . . . . . In Line, Behind  
Access Door, Near Light

Air Suspension Compressor 30A Circuit Breaker . . . . . In Fuse Block



## ONAN MOTOR GENERATOR (6000 WATT—50 AMP)

Bore . . . . .	3 9/16 in.
Stroke . . . . .	3 in.
Oil Capacity . . . . .	4 Qt.
	(With Filter Change) 4 1/2 Qt.
Spark Plug Type . . . . .	ACR46S
Spark Plug Gap . . . . .	.020 in.
Breaker Point Gap . . . . .	.020 in.
Ignition Timing (Running or Static) . . . . .	25° BTDC
Tappet Adjustment (Engine Cold)	
Intake . . . . .	.003 in.
Exhaust . . . . .	.012 in.

## LIGHT BULB SPECIFICATIONS (INSTRUMENT PANEL)

<u>Usage</u>	<u>Quantity</u>	<u>Bulb No.</u>
Brake System Tell Tale	1	161
Generator Tell Tale	1	161
Park Brake Tell Tale	1	74
Cruise Control Tell Tale	1	74
Door Ajar Tell Tale	1	74
Low Fuel Tell Tale	1	74
Low Air Tell Tale	1	74
Power Level Tell Tale	2	74
High Beam Indicator	1	161
Turn Signal Indicator	2	168
Instrument Cluster Lights	2	194
Speedo Cluster Lights	2	194
Dome Lights	2	211
Radio Dial (AM/FM/Stereo/Tape)	1	566
Radio Dial (Exc. AM/FM/Stereo/Tape)	1	1893
Heater Control	1	1895

## LIGHT BULB SPECIFICATIONS (EXTERIOR)

<u>Usage</u>	<u>Quantity</u>	<u>Bulb No.</u>
Clearance and I.D.	10	67
License	1	67
Side Markers—Front	2	194
Side Markers—Rear	2	194
Back-up Lights	2	1156
Parking and Turn Signals	2	1157
Stop and Tail	2	1157
Headlights	2	6014

# OWNER ASSISTANCE

The satisfaction and goodwill of the owners of GMC Truck & Coach products are of primary concern to your dealer and the GMC Truck & Coach Division. Normally, any problems that arise in connection with the sales transaction or the operation of your vehicle will be handled by your dealer's Sales or Service Departments. It is recognized, however, that despite the best intentions of everyone concerned, misunderstandings will sometimes occur. If you have a problem that has not been handled to your satisfaction through normal channels, we suggest that you take the following steps:

**STEP ONE**—Discuss your problem with a member of dealership management. Frequently, complaints are the result of a breakdown in communications and can quickly be resolved by a member of the dealership management. If the problem already has been reviewed with the Sales Manager or Service Manager, contact the Dealer himself or the General Manager.

**STEP TWO**—Contact the GMC Truck & Coach Division Zone Office closest to you listed on page 74 (or in Canada contact the general Motors Zone Office). When it appears that your problem cannot be readily resolved by the service outlet without additional assistance, the matter should be called to the attention of the Zone's Customer Services Department and the following information provided:

- Your name, address, telephone number
- Vehicle Identification Number\*
- Dealer's name and location
- Vehicle's delivery date and mileage
- Nature of problem

**STEP THREE**—Contact the Customer Services Manager, GMC Truck & Coach Division, 660 South Blvd. East, Pontiac, Michigan 48053 (phone 313-857-4547). In Canada, contact the Owner Relations Manager, General Motors of Canada Limited, Oshawa, Ontario (phone 416-644-6624). If after an additional review of all facts involved he feels that some further action can be taken, he will so instruct the Zone. In any case, your letter will be acknowledged providing GMC Truck & Coach Division's position in the matter.

When contacting the Zone or Home Office, please bear in mind that ultimately your problem likely will be resolved in the dealership utilizing the dealer's facilities, equipment and personnel. It is suggested, therefore, that you follow the above steps in sequence when pursuing a problem.

Your purchase of a GMC Truck & Coach product is greatly appreciated by both your dealer and GMC Truck & Coach Division. It is our sincere desire to assist you in any way possible to assure your complete satisfaction with your vehicle.

\*Available from vehicle registration, title or vehicle identification plate.

# U.S. ZONE TERRITORIES

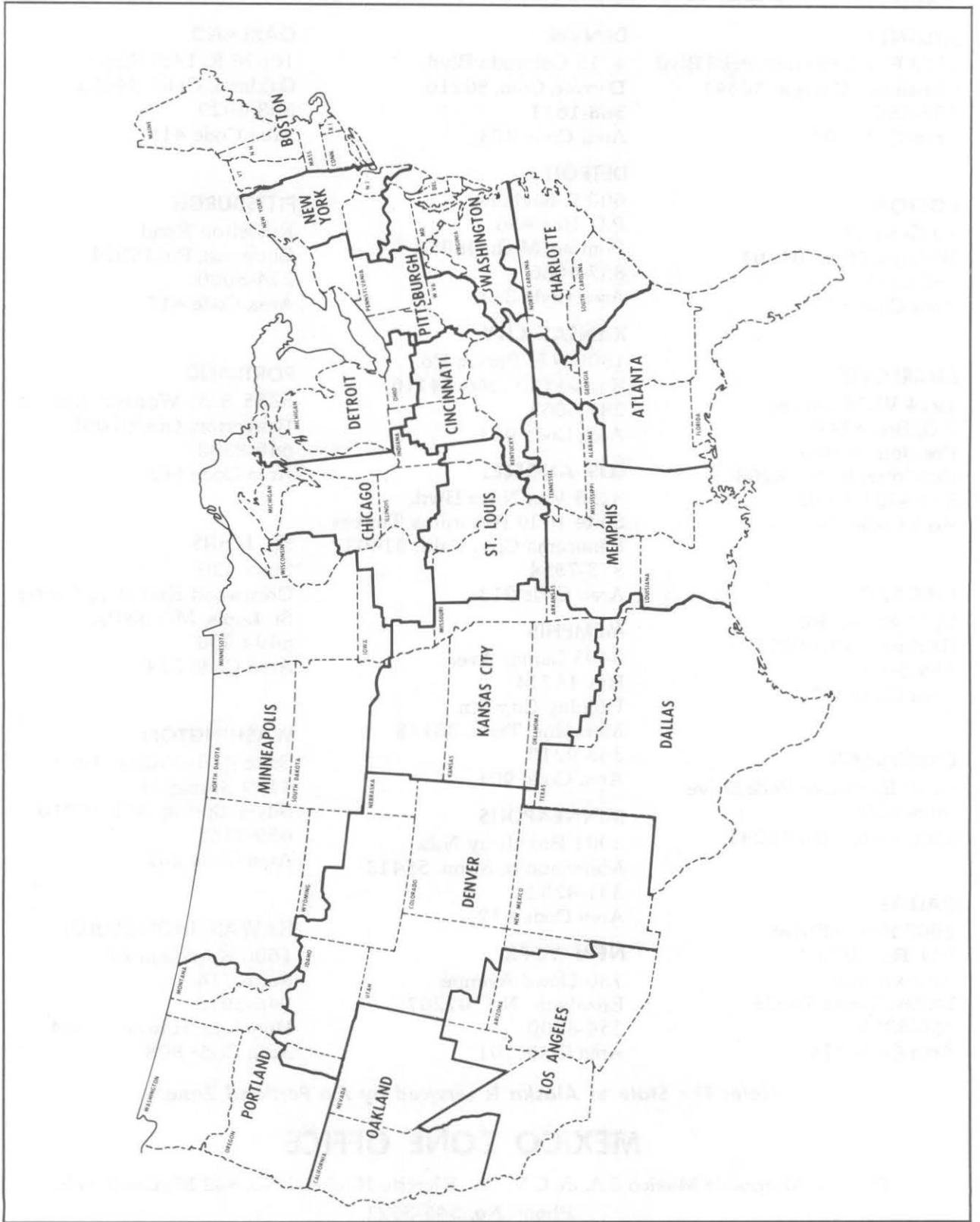

## U.S. ZONE OFFICES

*When calling for assistance, please ask for Customer Services Manager*

### ATLANTA

5373 Peachtree Industrial Blvd.  
Chamblee, Georgia 30341  
455-5564  
Area Code 404

### BOSTON

20 Cross St.  
Woburn, Mass. 01801  
935-6858  
Area Code 617

### CHARLOTTE

1914 W. Morehead  
P.O. Box 8149  
Freedom Station  
Charlotte, N. C. 28208  
332-4181-82-83  
Area Code 704

### CHICAGO

2021 Spring Rd.  
Oakbrook, Ill. 60521  
654-6465  
Area Code 312

### CINCINNATI

4010 Executive Park Drive  
Suite 320  
Cincinnati, Ohio 45241

### DALLAS

6007 Peeler Street  
P.O. Box 35187  
Airlawn Station  
Dallas, Texas 75235  
358-5316  
Area Code 214

### DENVER

4715 Colorado Blvd.  
Denver, Colo. 80216  
388-1611  
Area Code 303

### DETROIT

600 S. Saginaw  
P.O. Box 456  
Pontiac, Mich. 48053  
857-4686  
Area Code 313

### KANSAS CITY

1509 N.E. Parvin Rd.  
Kansas City, Mo. 64116  
281-6063  
Area Code 913

### LOS ANGELES

8155 Van Nuys Blvd.  
Suite 1030 Panorama Towers  
Panorama City, Calif. 91402  
873-7554  
Area Code 213

### MEMPHIS

3495 Lamar Ave.  
Box 18714  
Holiday City Sta.  
Memphis, Tenn. 38118  
365-9210  
Area Code 901

### MINNEAPOLIS

3001 Broadway N.E.  
Minneapolis, Minn. 55413  
331-4282  
Area Code 612

### NEW YORK

780 Dowd Avenue  
Elizabeth, N.J. 07207  
354-8200  
Area Code 201

### OAKLAND

10626 E. 14th Street  
Oakland, Calif. 94603  
568-6929  
Area Code 415

### PITTSBURGH

Russelton Road  
Cheswick, Pa. 15024  
274-8000  
Area Code 412

### PORTLAND

5355 S.W. Western Avenue  
Beaverton, Ore. 97005  
646-8333  
Area Code 503

### ST. LOUIS

Suite 320  
Crestwood Executive Center  
St. Louis, Mo. 63126  
849-0990  
Area Code 314

### WASHINGTON

Suite 410—Profess. Bldg.  
1109 Spring St.  
Silver Spring, Md. 20910  
659-3166  
Area Code 202

### HAWAII (HONOLULU)

1600 Kapiolani Blvd.  
Suite 714  
946-3988  
Honolulu, Hawaii 96814  
Area Code 808

*Note: The State of Alaska is serviced by the Portland Zone.*

## MEXICO ZONE OFFICE

General Motors de Mexico S.A. de C.V. Av. Ejercito Nacional No. 843 Mexico 5, D.F.  
Phone No. 545-3921

**GM OF CANADA LIMITED—ZONE OFFICES**

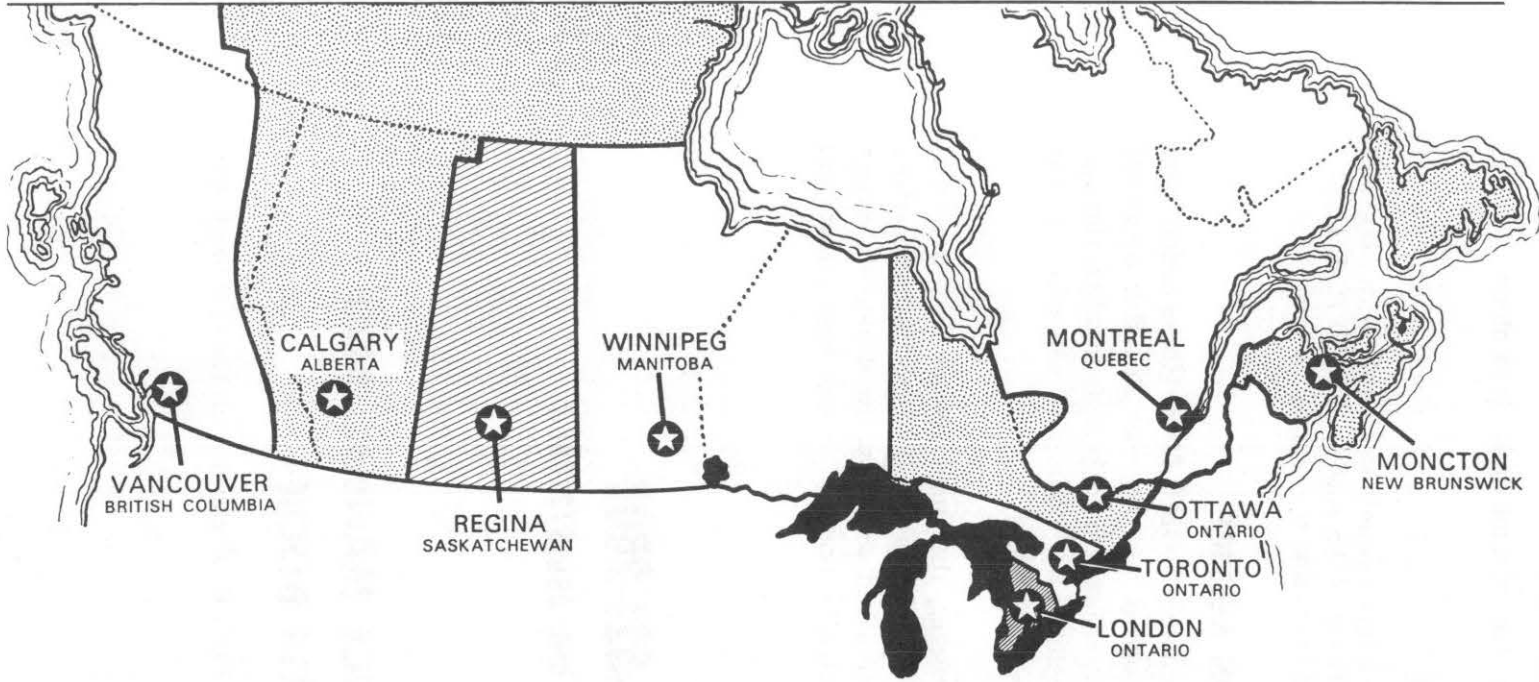

75

ZONES	ADDRESS	AREA CODE	PHONE NO.
VANCOUVER	900 Terminal Avenue Vancouver, B.C. V6A 2N6	604	684-9444
CALGARY	Box 2510 Calgary, Alberta T2P 2M7	403	243-4621
REGINA	581 Park Street Regina, Sask. S4P 3E9	306	643-2224
WINNIPEG	1345 Redwood Avenue Winnipeg, Man. R2X 0Y9	204	633-1080
LONDON	1991 Oxford St. E. London, Ontario N6A 4P6	519	455-2400

ZONES	ADDRESS	AREA CODE	PHONE NO.
TORONTO	1200 Eglinton Ave. East Don Mills, Ont. M3C 1J1	416	446-5053
OTTAWA	875 Belfast Road Ottawa, Ont. K1G 0Z4	613	237-5051
MONTREAL	5000 Trans-Canada Hwy. Pointe Claire, Quebec H9R 4R2	514	697-9160
MONCTON	653 St. George Street Moncton, N.B. E1C 8M2	506	854-1500

## **24-HOUR PHONE ASSISTANCE**

- Need answers to service or maintenance questions?
- Want to discuss vehicle specifications?
- Want to know where the GMC MotorHome dealer is located?

### **NORMAL BUSINESS HOURS**

GMC offers you direct-to-factory communication. You can dial toll free Monday through Friday between 8:15 A.M. and 5:00 P.M. (EST) and talk with qualified personnel by calling the number below.

### **AFTER-HOUR INFORMATION SERVICE**

If you have attempted to contact a GMC MotorHome dealer after normal business hours, without success, you may call the toll-free number below. The operator who will answer has a list of private numbers through which many dealers can be reached after hours and will give you the number and location of the nearest one.

It should be understood, however, that any charges for after-hours service assistance must be borne by the owner. In those instances where the repair qualifies under our published warranty, the dealership charge for additional services, such as for, after normal business hour repairs will be the owner's expense.

**800-521-2806**

**In Michigan call: 800-572-7959**

## **MAINTENANCE MANUAL AND PARTS BOOK**

Maintenance Manual and/or Parts Book can be purchased through any GMC MotorHome dealer.

# IMPORTANT FACTS YOU SHOULD KNOW ABOUT GASOLINE MILEAGE AND HOW TO IMPROVE IT

How you drive, where you drive, and when you drive all have an effect on how many miles you can get from a gallon of gasoline. The careful attention you give your vehicle as far as maintenance and repairs are concerned will also contribute importantly to fuel economy.

## FUEL SELECTION

Use a gasoline of at least 87 average octane number (Research octane plus Motor octane divided by two). The gasoline should have a Research octane number of at least 91, and a Motor octane number of at least 83.

Additional details on Fuel Requirements are given in the **SERVICE AND MAINTENANCE** section.

## "JACKRABBIT" STARTS

Gasoline can be conserved (and engine and tire life prolonged) by avoiding unnecessarily rapid acceleration away from lights and stop signs.

## STOP-AND START DRIVING

Frequent stops and starts during a trip really cut down on your miles per gallon. Plan even your short trips to take advantage of through streets to avoid traffic lights. Pace your driving like the professional drivers to avoid unnecessary stops.

## EXCESSIVE IDLING

An idling engine uses gasoline, too. If you're faced with more than a few minutes wait and you're not in traffic, it may be better to "turn off" and start again later.

## SUDDEN STOPS

Sudden stops themselves don't waste gasoline, but energy is wasted as heat in braking. Energy in the form of gasoline is also needed to accelerate back to driving speed.

## LUBRICANTS

A properly lubricated vehicle means less friction between moving parts. Consult this manual and the maintenance schedule for the proper lubricants to use and the lubrication intervals.

## AIR CLEANER

Your vehicle receives its power from a mixture of gasoline and air. The air is taken into the system through the air cleaner so it's important to replace the air cleaner at required intervals. A dirty air cleaner reduces engine efficiency.

## PROPERLY TUNED ENGINE

Overall tuning (a check on timing, spark plugs, emission control devices, etc.) can improve your vehicle's gas mileage. You just can't expect an "out-of-tune" engine to give you good gas mileage and cleaner air.

## EXCESS WEIGHT

Fuel economy is related to the work the engine must do. The heavier the load, the more power it takes. Keep excess weight to a minimum by removing any personal effects or luggage from the vehicle when they are not needed.

## TIRE INFLATION

Underinflation not only causes needless wear of the tires, but can also waste gasoline. It's a good idea to check tire pressures regularly.

## WHEEL ALIGNMENT

"Toe in" or "toe out" has the effect of dragging your front tires sideways and causes premature tire wear. It takes power to carry this extra load and that takes gas from your tanks.

# INDEX

SUBJECT	PAGE NO.	SUBJECT	PAGE NO.
<b>A</b>			
Absorbers, Shock .....	65	Capacities .....	68
Accessory Position, Ignition Switch .....	12	Carbon Monoxide Caution .....	10, 11
After-Hour Information Service .....	76	Carburetor, Engine .....	57
Air Circulation .....	24 - 26	Changing Wheels & Tires .....	35, 61-64
Air Cleaner .....	57, 69	Charging System Indicator Light .....	21
Air Compressor .....	65	Chassis Lubrication .....	51, 53
Air Conditioning		Check List .....	5
Automotive .....	25	Child Restraints .....	8
Air Suspension .....	65	Chrome Protection .....	43
Alignment, Wheel .....	69	Cigar Lighter .....	24
Antenna .....	27	Circuit Breaker, Headlights .....	19, 70
Anti-theft Steering Column Lock .....	12	Circuit Breaker .....	19, 70
Appearance Care .....	39	Cleaning	
Automatic Transmission		Exterior Finish and Trim .....	43
Fluid Check .....	50	Fabric and Interior Trim .....	41
Maintenance .....	50, 52	Spot Removal .....	42
Operation .....	14	Cold Weather Starting .....	13
Starter Safety Switch .....	13	Compartment	
Auxiliary Battery .....	23, 58, 68	Engine .....	47
Auxiliary Fuel Tank .....	23	Front Access .....	46
Axle, Final Drive .....	53	Glove .....	5
<b>B</b>			
Batteries		Complaint Procedure .....	72
Emergency Starting .....	33	Conditioner, Automotive, Air .....	25
Fluid Level .....	58	Cooling System	
Gas Caution .....	59	Care .....	54
Location .....	58	Coolant Recommendation .....	54
Battery Boost Switch .....	23	Overheating Caution .....	35
Bearings, Rear Wheel .....	64	Cruise Control .....	14
Before Driving .....	5	Customer Service .....	72
Belts, Lap .....	7, 39	<b>D</b>	
Blower, Ventilating .....	24, 25	Defrosters .....	24, 25
Body Identification Number .....	67	Differential, Final Drive .....	53
Brakes		Dimensions, Vehicle .....	68
Linings .....	18	Dimmer Switch, Headlamp .....	19
Master Cylinder Level .....	53	Directional Signal .....	15
Parking Brake .....	18	Distributor .....	59
Power .....	17	Dome Lights .....	22
Self-Adjusting .....	18	Driver Check List .....	5
Trailer .....	9	Driver's Seat .....	6
Warning Light .....	21	Dusty Condition, Operation Under ...	31, 57
Bright Metal Cleaning .....	43	<b>E</b>	
Bulbs and Fuses .....	70, 71	Electrical Systems	
<b>C</b>			
Cap, Filler		Batteries .....	23, 58, 68
Engine Oil .....	45	Battery Boost Switch .....	23
Gasoline .....	57	Bulbs, Light .....	71
Power Steering Reservoir .....	52	Charging System Indicator Light .....	21
Radiator .....	54	Diode Assembly .....	23
<b>E</b>			
		Emergency Exit .....	38, 39



SUBJECT	PAGE NO.	SUBJECT	PAGE NO.
Emergency, In Case Of . . . . .	33	Front Suspension . . . . .	65
Brake System Warning Light . . . . .	21	Fuel	
Charging System Warning Light . . . . .	21	Filler Cap Location . . . . .	57
Emergency Starting . . . . .	33	Gauge . . . . .	19
Hazard Warning Flasher . . . . .	33	Recommendation . . . . .	56
Jacking Instructions . . . . .	35	Tank Selector Switch . . . . .	23
Jump Starting . . . . .	33	Fumes, Engine Exhaust . . . . .	10, 11
Overheated Engine . . . . .	35	Fuses	
Power Level System . . . . .	29	Vehicle Chart . . . . .	70
Pushing to Start . . . . .	33	Vehicle Location . . . . .	60
Towing . . . . .	37		
Engine Access . . . . .	47	<b>G</b>	
Engine Coolant Reservoir . . . . .	54	Gas Station Information . (Inside Back Cover)	
Engine Compartment . . . . .	47	Gasoline (See Fuel) . . . . .	56
Engine Oil		Generator Indicator Light . . . . .	21
Capacity . . . . .	68	General Data & Specifications . . . . .	67
Dip Stick . . . . .	50	Glass and Mirrors . . . . .	5, 30, 40, 43
Filter . . . . .	49, 69	Glove Box . . . . .	5
Pressure Gauge . . . . .	20	Gross Vehicle Weight (GVW) . . . . .	2
Recommendation . . . . .	49		
Entrance Door . . . . .	7	<b>H</b>	
Ethylene Glycol Coolant . . . . .	54	Hazard Warning Flasher . . . . .	33, 70
Exhaust Gas Caution . . . . .	10, 11	Headlight	
Parked with Engine Running . . . . .	11	Adjustment . . . . .	60
Exit, Emergency . . . . .	38, 39	Flicker . . . . .	19
Exterior Finish Care . . . . .	43	High Beam Dimmer Switch . . . . .	19
		High Beam Indicator . . . . .	19
<b>F</b>		Replacement . . . . .	60
Fabric Care . . . . .	41	Switch . . . . .	22
Filters . . . . .	49, 69	Heater, Operation . . . . .	24
Final Drive Differential . . . . .	53	Hitches, Trailer . . . . .	9
Finish Care, Exterior . . . . .	43	Hoisting Vehicle . . . . .	48
Flammable Cleaning Solvents . . . . .	41	Horn . . . . .	15
Flashers			
Hazard Warning . . . . .	33, 70	<b>I</b>	
Turn Signal . . . . .	15, 70	Identification Lights . . . . .	22, 71
Flooded Engine . . . . .	13	Identification Number, Vehicle . . . . .	67
Floor Controls . . . . .	17	Identificaiton Plate, Vehicle . . . . .	3
Fluid Capacities . . . . .	68	Ignition, Keys and Lock . . . . .	5, 7
Fluid Levels		In Case of Emergency . . . . .	33
Batteries . . . . .	58	Indicator Lights . . . . .	29
Brake Master Cylinder . . . . .	53	Infant Restraining Methods . . . . .	8
Engine Oil . . . . .	49	Inflation Pressure, Tire . . . . .	61
Final Drive . . . . .	53	Instrument Panel . . . . .	19
Power Steering . . . . .	53	Interior Appearance Care . . . . .	39
Radiator . . . . .	54		
Transmission . . . . .	50	<b>J</b>	
Foreign Countries, Operation in . . . . .	9	Jack Usage Instructions . . . . .	35
Four-Way Hazard Warning Flasher . . . . .	33	Jump Starting . . . . .	33
Front Access Doors . . . . .	46		

SUBJECT	PAGE NO.
<b>K</b>	
Keys .....	5
Knocking Engine .....	56
<b>L</b>	
Lane Change and Turn Signal .....	15
Lap Belts .....	7, 8
Latch, Door .....	7
Leveling, Vehicle .....	28
Lighter, Cigar .....	24
Lights	
Brake Warning .....	21
Bright Beam Indicator .....	19
Bulb Chart .....	71
Charging System .....	21
Dome .....	22
Hazard Flasher .....	33
Headlight Switch .....	22
Marker & Clearance .....	22
Parking Brake .....	22
Tail Lights .....	22
Tell Tale Warning .....	21
Turn Signal Indicator .....	15
Linings, Brake .....	18
Loading, Vehicle .....	2
Locks .....	5
Low Temperature Operation .....	13
Lubrication Details .....	49
<b>M</b>	
Maintenance	
Appearance Care .....	39
Manual .....	76
Master Cylinder, Brake .....	53
Marker Lights .....	22
Metal Cleaners .....	43
Methods of Restraining Children .....	8
Mirrors, Rear View .....	5
Mobile Radio Transmitter .....	28
<b>O</b>	
Odometer .....	19
Oil	
Additives .....	49
Checking Engine Oil Level .....	49
Pressure Gauge .....	20
Recommendations .....	49
Transmission .....	50
Viscosity .....	49
Operation in Foreign Countries .....	9

SUBJECT	PAGE NO.
Overheated Engine	
Temperature Gauge .....	19
What To Do .....	19
Owner Assistance .....	72
<b>P</b>	
Paint, Care and Touch Up .....	44
Parking .....	12
Brake .....	18
Lights .....	22
Plugs, Spark .....	59, 68
Polishing and Waxing .....	43
Power	
Brakes .....	17
Level System .....	28
Steering .....	15
Pressure, Tire Inflation .....	61
<b>R</b>	
Radiator and Coolant .....	54
Radio	
AM .....	26
AM/FM .....	26
Antenna .....	27
Mobile Transmitter .....	28
Stereo .....	27
Tape System .....	27
Raising Vehicle With Jack .....	35
Rear Suspension .....	65
Rear Wheel Bearings .....	64
Restraints, Child .....	8
Rotation, Tire .....	63
<b>S</b>	
Safety	
Belts, Lap .....	7, 8
Schedule, Maintenance .....	45
Screen, Window .....	40
Seat	
Adjustments .....	6
Belts .....	7
Self Adjusting Brakes .....	18
Service and Maintenance .....	45
Service Assistance, After-Hour .....	76
Shock Absorbers .....	65
Signals, Turn .....	15
Solvents, Recommended Cleaning .....	41
Spark Knock .....	56
Spark Plugs .....	59, 68
Speakers, Radio .....	26, 27

SUBJECT	PAGE NO.	SUBJECT	PAGE NO.
Specifications		Transmission	
Air Cleaner	69	Braking Effect On Hills	14
Body	67	Checking Fluid Level	50
Capacities	68	Maintenance	50
Dimensions	68	Shift Controls	13
Filters	69	Transmitter, Mobile Radio	28
Fuses	70	Tread Wear Indicators	63
Light Bulbs	71	Trim Care Interior	39
Miscellaneous	69	Turn Signals	15
PCV Valve	69	<b>U</b>	
Vehicle Identification	67	Underbody Maintenance	66
Speedometer and Odometer	19	Undercoating	44, 66
Spot Cleaner	39	Upholstery	39
Stains, Removal Of	42	<b>V</b>	
Starter, Safety Switch	13	Vehicle Identification	3, 67
Starting Engine	13	Volatile Cleaning Solvents, Caution	41
Cold Weather	13	<b>W</b>	
Emergency	33	Warning Flasher, Hazard	33
Steering		Warning Lights	
Column Controls	12	Brake	21
Linkage	53	Charging System	21
Maintenance	53	Cluster	21
Power	15, 53	Low Fuel	22
Tilt	15	Washers, Windshield	23
Wheel	15	Washing	43
Stereo, Radio and Tape	27	Waxing	43
Suspension		Weight Distribution	2
Front	65	Wheel Alignment	69
Rear	65	Wheel Bearings	
Swivel Seats	6	Front	64
<b>T</b>		Rear	64
Tape System, Stereo	27	Wheel Changing	35, 62
Tell Tale Lights	21	Wheel, Tilt Steering	15
Temperature		Windows	29
Control, Cooling and Heating	24 - 26	Latch	30
Gauge	19	Screen	40
Thermostat, Engine Cooling	56, 69	Windshield	
Tilt Steering Wheel	15	Defrosting	24 - 26
Tire		Washers	23
Care	61	Wipers	23
Changing	35, 62	Wrecker, Towing	37
Inflation Pressure	61	<b>Z</b>	
Inspection	63	Zone Offices	
Load Limit	62	Canada	75
Replacement	62	Mexico	74
Rotation	63	United States	74
Snow	63	Zone Territories	
Traction	63	Canada	75
Tread Wear	63	United States	73
Towing	37		
Trailer Hauling	9		

# GAS STATION INFORMATION

Refer to SERVICE AND MAINTENANCE section for details on removal and installation of engine cover, placing vehicle on suitable hoist, etc.

## CAUTION

To help prevent the possibility of fire or explosion, turn off LP gas supply at the LP gas tank and be sure all pilots are out, before filling gasoline tanks.

Always check that fluid inputs are made into the correct filler opening to help avoid serious personal injury and property damage.

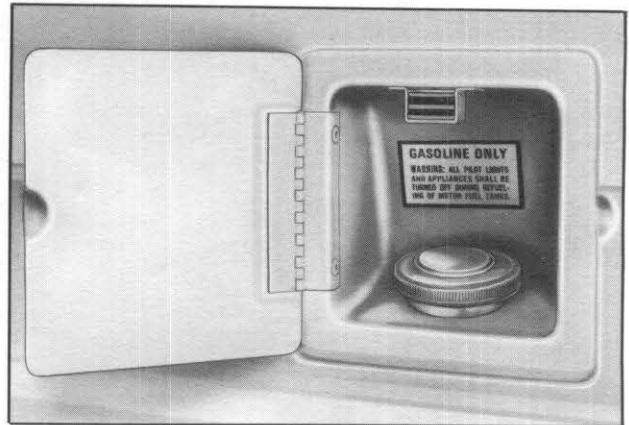

**TIRE INFLATION PRESSURES**—Check at least monthly. Keep inflated to pressures shown on tire placard affixed on the inside of the glove compartment door.

**GAS CAP**—Located on the left side of the vehicle, directly under the driver's window. See gas cap removal procedure in SERVICE AND MAINTENANCE section.

**WINDSHIELD WASHER**—Check reservoir fluid level regularly. Use a washer fluid, such as GM Optikleen.

**GASOLINE RECOMMENDATION**—Use an unleaded fuel of at least 91 Research Octane—Symbol Number 2. Additional details on Fuel Requirements are given in the SERVICE AND MAINTENANCE section.

**ENERGIZER (BATTERIES)**—Check fluid level monthly. Add only colorless, odorless drinking water or distilled water to bring level to split ring in filler opening.

**FRONT ACCESS DOORS**—Release by turning latch knob to the left to loosen.

**ENGINE OIL DIPSTICK**—Located inside the left front access door. Check oil level as the last operation in a fuel stop. Maintain between "ADD" and "FULL" marks on dipstick.

**ENGINE OIL RECOMMENDATION**—Use only high quality SE oils. The chart in the SERVICE AND MAINTENANCE section will serve as a guide for selecting proper oil viscosity.



# GAS STATION INFORMATION

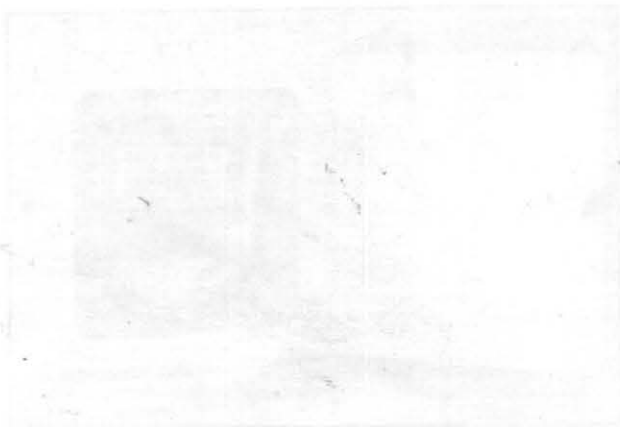

THE FRONT FENDER PRESSURE RELEASE VALVE IS LOCATED ON THE FRONT FENDER. KEEP THIS VALVE CLOSED AT ALL TIMES. IF THE VALVE IS OPENED, THE PRESSURE WILL BE RELEASED AND THE FRONT FENDER WILL BE DAMAGED.

WASHER FLUID RESERVOIR  
WASHER FLUID RESERVOIR IS LOCATED ON THE FRONT FENDER. ADD FLUID TO THE RESERVOIR AS NEEDED.

WASHER FLUID RESERVOIR (BATTERY-OPERATED)  
WASHER FLUID RESERVOIR (BATTERY-OPERATED) IS LOCATED ON THE FRONT FENDER. ADD FLUID TO THE RESERVOIR AS NEEDED.



SERVICE AND MAINTENANCE  
FOR DETAILS ON SERVICE AND MAINTENANCE, SEE THE SERVICE AND MAINTENANCE MANUAL.

TO OBTAIN A COPY OF THE SERVICE AND MAINTENANCE MANUAL, CONTACT THE DEALER OR THE SERVICE AND MAINTENANCE DEPARTMENT. THE MANUAL IS AVAILABLE FOR PURCHASE OR AS A FREE INFORMATIONAL COPY.

GAS CAP LOCATED ON THE LEFT SIDE OF THE FRONT FENDER. TO REMOVE THE CAP, TURN IT COUNTERCLOCKWISE.

FOR MORE INFORMATION ON SERVICE AND MAINTENANCE, CONTACT THE DEALER OR THE SERVICE AND MAINTENANCE DEPARTMENT.

FRONT ACCESS DOOR  
FRONT ACCESS DOOR IS LOCATED ON THE FRONT FENDER. TO OPEN THE DOOR, PULL THE HANDLE.

ENGINE OIL DRAIN  
ENGINE OIL DRAIN IS LOCATED ON THE FRONT FENDER. TO DRAIN THE OIL, REMOVE THE DRAIN PLUG.

ENGINE OIL RECOMMENDATION  
FOR RECOMMENDATIONS ON ENGINE OIL, SEE THE SERVICE AND MAINTENANCE MANUAL. THE RECOMMENDED OIL GRADE IS 10W-30.